

PDB-0824

Power Distribution Board (24Vdc, 2 Amp, 8 channel)

Description

The PDB-0824 power distribution board enables easy distribution of 24Vdc from the main power rail to individual 24Vdc devices inside the cabinet enclosure, such as fan units and FTAs.

Figure 496 on page 792 shows the PDB-0824 board with one 24Vdc entry connector (In) for connection to the main bus bar and eight (2 Amp fused) 24Vdc field connectors (Out1 thru Out8) for connection to eight 24Vdc devices.

Figure 496 PDB-0824 board layout

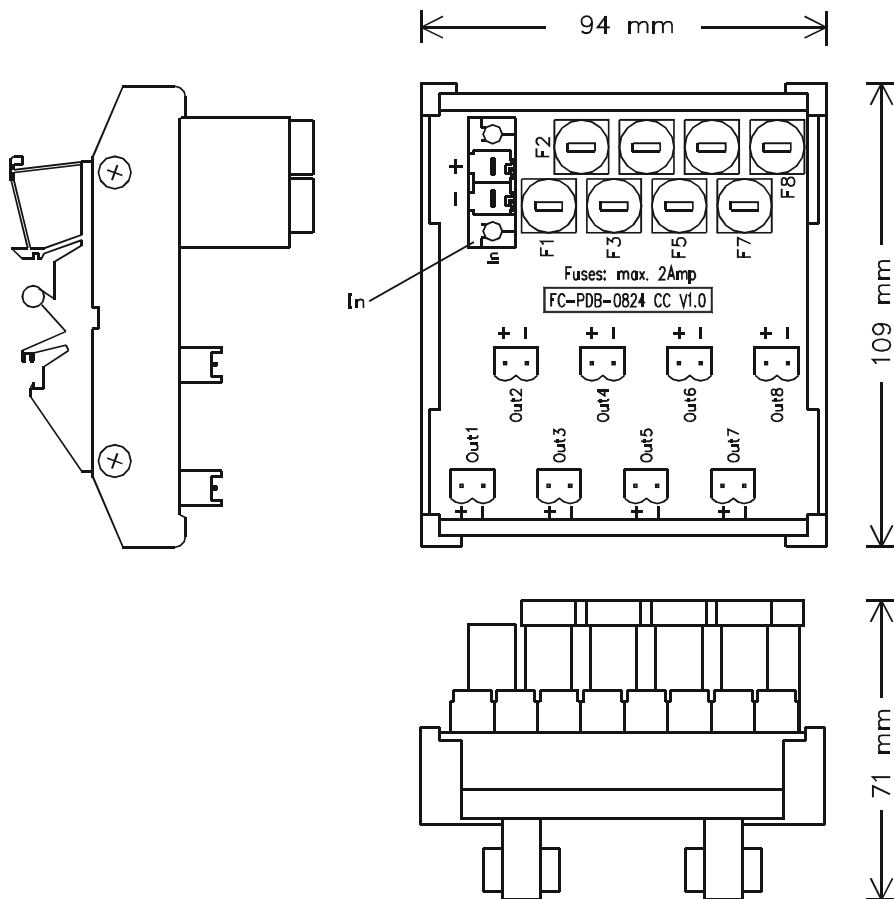

A 24 Vdc power distribution cable (see data sheet “PDC-MB24-x” on page 812 for details) can be used to connect the main power bar to In.

- When using other connection cables make sure the wire size is adequate and a Weidmuller BVZ 7.62/02F SW connector with two keying pins is used to connect to In of the PDB-0824 (see “Pin allocation” on page 793).

24V distribution cables (see “PDC-FTA24” on page 816) connect the PDB-0824 with up to eight 24Vdc devices.

- When using other connection cables make sure the wire size is adequate and a Weidmuller BL 5.08/2 SN OR or equivalent connector is used to connect to one of the Outx connectors of the PDB-0824 (see “Pin allocation” on page 793).

Pin allocation

Figure 497 on page 793 shows the top, side & bottom view and the pin assignment of the Weidmuller BVZ 7.62/02F SW cable-connector on In.

1. The pin marked “+” is pin 1; connect to +24Vdc wire to the main bus bar
2. The pin marked “-” is pin 2; connect to 0Vdc wire to the main bus bar

Figure 497 Power connector on In (Weidmuller BVZ 7.62/02F SW) top, side and bottom view

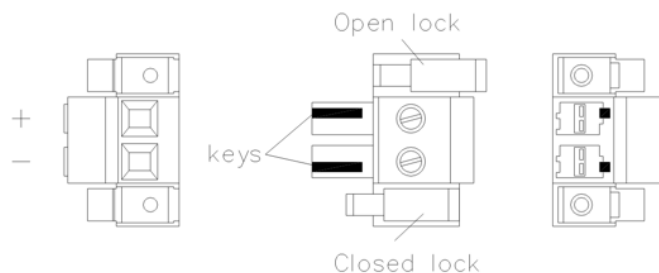

The two (orange) locking slides of the cable-connector in Figure 497 on page 793 keep the cable-connector locked when inserted into In.

Figure 498 on page 793 shows the top, side & bottom view and the pin assignment of the Weidmuller BL 5.08/2 SN OR or equivalent connector to an Outx field connector on the PDB-0824.

1. The pin marked “+” is pin 1; connect to +24Vdc wire to the consumer
2. The pin marked “-” is pin 2; connect to 0Vdc wire to the consumer

Figure 498 Power connector on Outx (Weidmuller BL 5.08/2 SN OR) top, side and bottom view

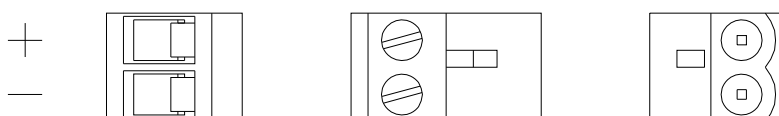

Connections

The connection diagram of the PDB-0824 module:

Figure 499 Connection diagram

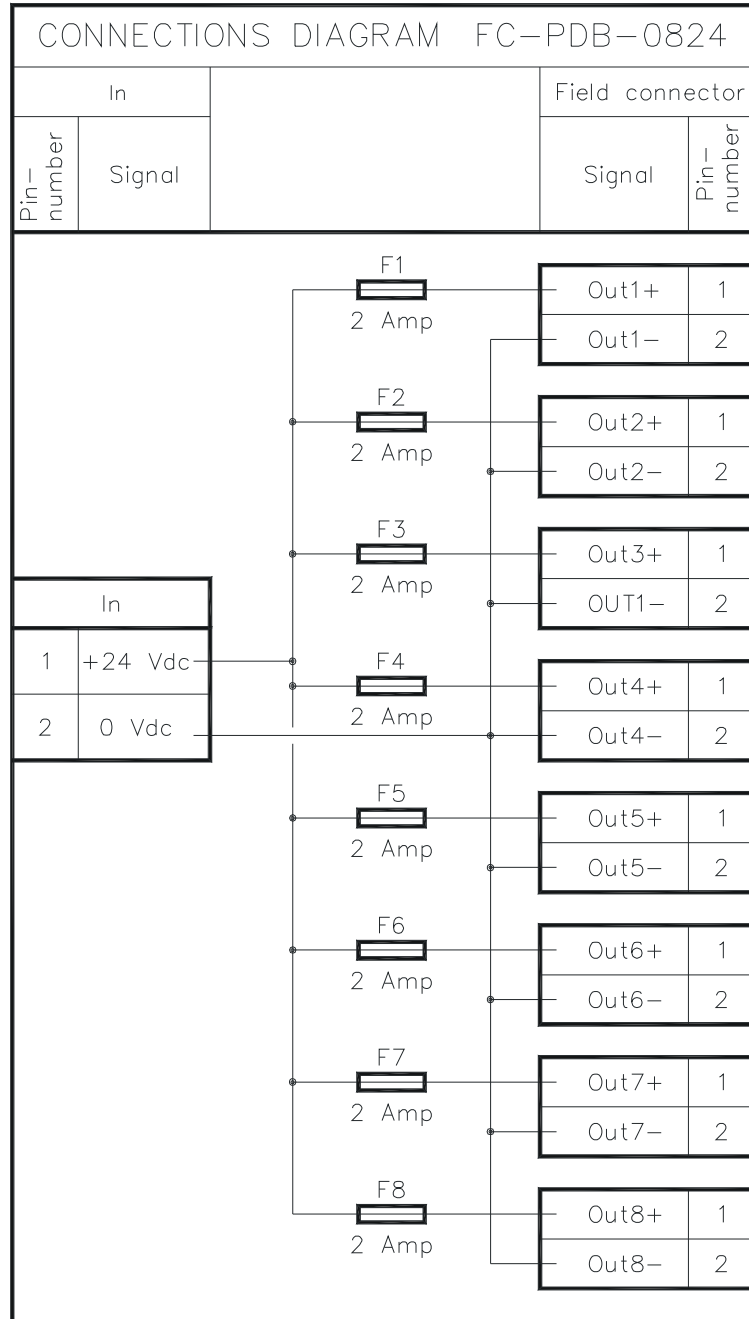

Technical data

General	Type numbers ¹ :	FC-PDB-0824 CC V1.0
	Approvals:	CE; UL, TUV, CSA pending
Fuses	rating	max. 2 AT (slow acting)
	dimensions:	5 x 20 mm (0.20 x 0.79 in)
Connectors	In make and type:	2 pole header with keying <ul style="list-style-type: none"> • Weidmuller: BVZ 7.62/02F SW (conn.) • Weidmuller: KO BV/SV7.62 (keys)
	Field connector make and type:	2 pole socket block Weidmuller: BL 5.08/2 SN OR
Physical	Module dimensions:	94 x 109 x 71 mm (L x W x H) 3.7 x 4.3 x 2.8 in (L x W x H)
	DIN EN rails:	TS32 / TS35 × 7.5
	Used rail length:	95 mm (3.74 in)

¹ FC-type modules are conformal coated modules. Conformal coated modules have the letters "CC" preceding the version number.

PDB-0824P

Power Distribution Board (24Vdc, 2 Amp, 8 channel)

Description

The PDB-0824P power distribution board enables easy distribution of 24Vdc from the main power rail to individual 24Vdc devices inside the cabinet enclosure, such as fan units and FTAs.

Figure 500 on page 796 shows the PDB-0824P board with one 24Vdc entry connector (In) for connection to the main bus bar and eight (2 Amp fused) 24Vdc field connectors (Out1 thru Out8) for connection to eight 24Vdc devices.

Figure 500 PDB-0824P board layout

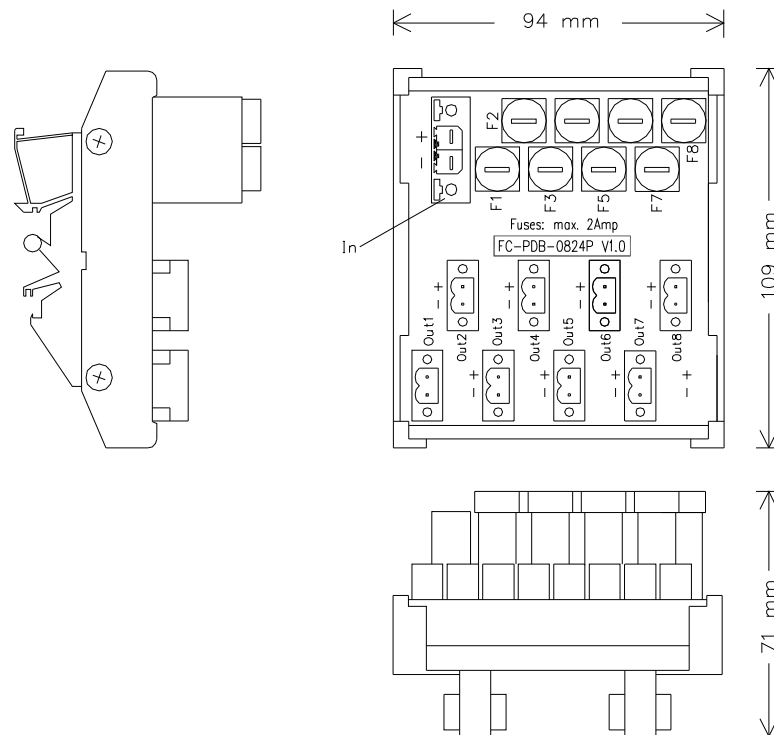

A 24 Vdc power distribution cable (see data sheet “PDC-MB24-y” on page 814 for details) can be used to connect the main power bar to In.

- When using other connection cables make sure the wire size is adequate and a Weidmuller BVZ 7.62HP/02F SN connector with two keying pins is used to connect to In of the PDB-0824P (see “Pin allocation” on page 797).

24V distribution cables (see “PDC-FTA24” on page 816) connect the PDB-0824P with up to eight 24Vdc devices.

- When using other connection cables make sure the wire size is adequate and a Weidmuller BLZ 5.08/2F SN SW or equivalent connector (e.g. BL 5.08/2 SN OR) is used to connect to one of the Outx connectors of the PDB-0824P (see “Pin allocation” on page 797).

Pin allocation

Figure 501 on page 797 shows the top, side & bottom view and the pin assignment of the Weidmuller BVZ 7.62HP/02F SN cable-connector on In.

1. The pin marked “+” is pin 1; connect to +24Vdc wire to the main bus bar
2. The pin marked “-” is pin 2; connect to 0Vdc wire to the main bus bar

Figure 501 Power connector on In (Weidmuller BVZ 7.62HP/02F SN) top, side and bottom view

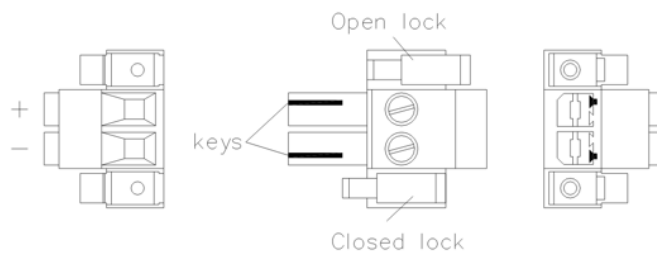

The two (red) locking slides of the cable-connector in Figure 501 on page 797 keep the cable-connector locked when inserted into In.

Figure 502 on page 797 shows the top, side & bottom view and the pin assignment of the Weidmuller BLZ 5.08/2F SN SW.

1. The pin marked “+” is pin 1; connect to +24Vdc wire to the consumer
2. The pin marked “-” is pin 2; connect to 0Vdc wire to the consumer

Figure 502 Power connector on Outx (Weidmuller BLZ 5.08/2F SN SW) top, side and bottom view

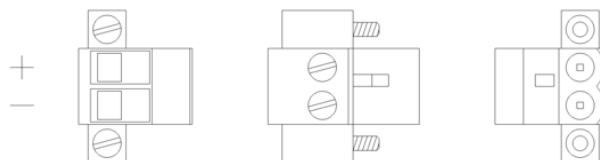

Connections

The connection diagram of the PDB-0824P module:

Figure 503 Connection diagram

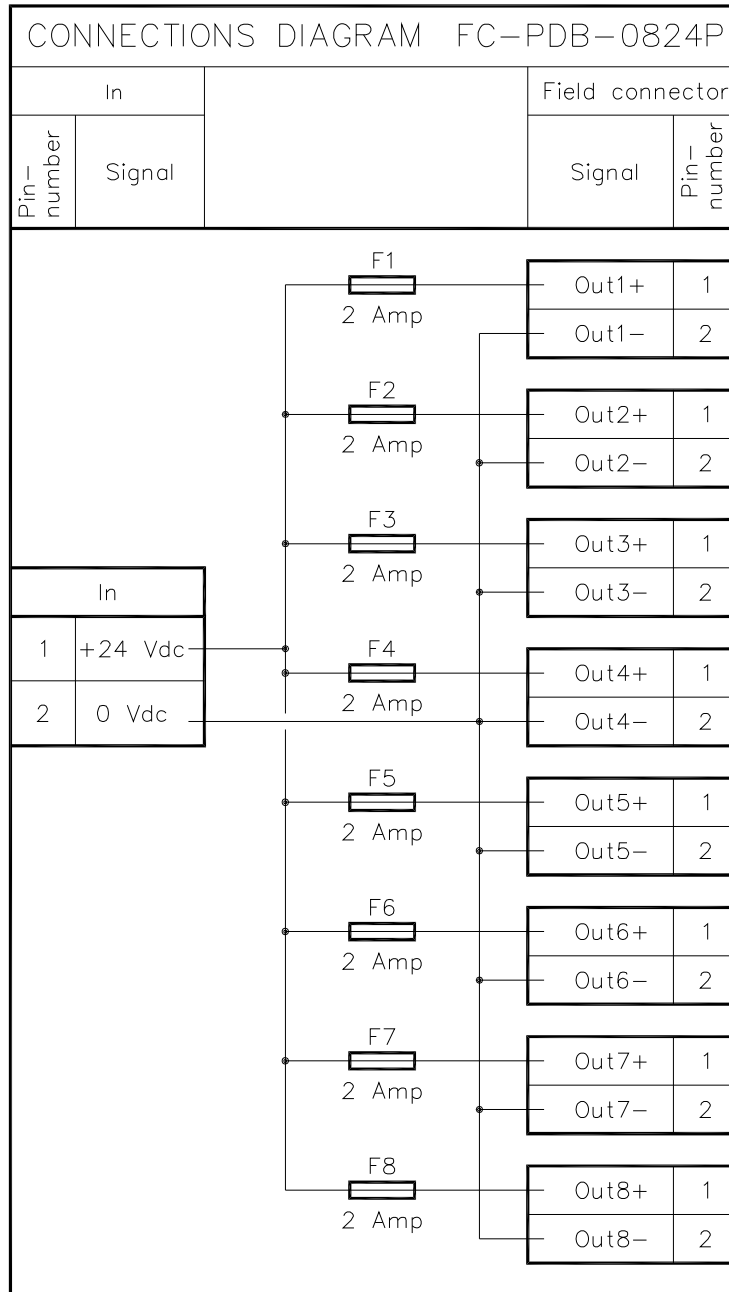

Technical data

General	Type number ¹ :	FC-PDB-0824P V1.0
	Approvals:	CE; UL, TUV, CSA pending
Fuses	rating	max. 2 AT (slow acting)
	dimensions:	5 x 20 mm (0.20 x 0.79 in)
Connectors	In make and type:	2 pole header with keying <ul style="list-style-type: none"> • Weidmuller: BVZ 7.62HP/02F SN (conn.) • Weidmuller: BV/SV7.62HP KO (keys)
	Field connector make and type:	2 pole socket block Weidmuller: BLZ 5.08/2F SN SW
Physical	Module dimensions:	94 x 109 x 71 mm (L x W x H) 3.7 x 4.3 x 2.8 in (L x W x H)
	DIN EN rails:	TS32 / TS35 × 7.5
	Used rail length:	95 mm (3.74 in)

1 FC-type modules are conformal coated modules.

PDC-MBMB-1

Mains power distribution cable (24Vdc, 48Vdc)

Description

The PDC-MBMB-1 power distribution cable transfers the 24Vdc or 48Vdc from one mains power rail of type FS-MB-0001 to another mains power rail of that type.

Figure 504 on page 800 shows the layout of the PDC-MBMB-1 power distribution cable.

Figure 504 Layout of PDC-MBMB-1 power distribution cable

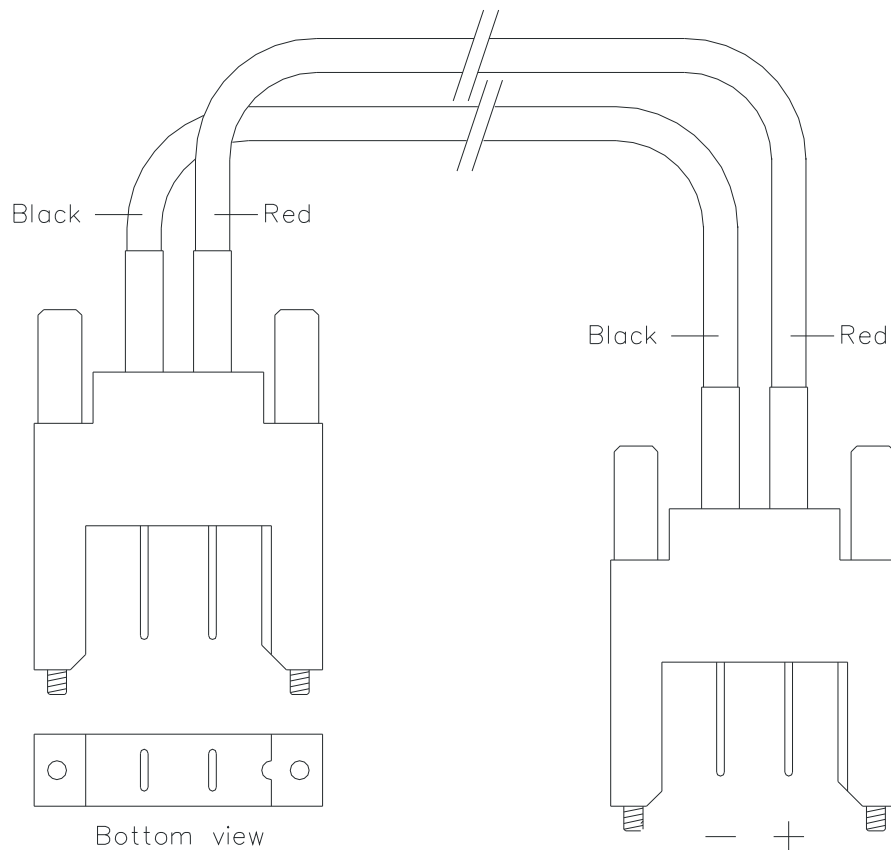

The cable plugs in the mains power rail with a polarized connector that must be locked on the rail using its two screws. To enable this, the plug must be placed on one of the rail positions that has nuts in the rail housing (see Figure 505 on page 801).

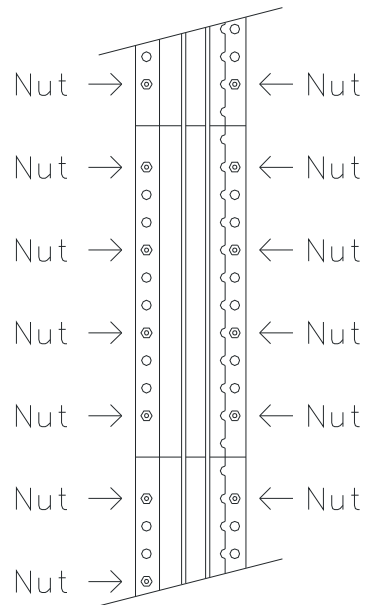
Figure 505 Section of the MB-0001 mains power rail

High loads

With second rail loads exceeding 30 Amp (up to 100 Amp) it is recommended to use two PDC-MBMB-1 cables to connect the two power rails.

- Connect the first cable close to the top of each power rail.
- Connect the second cable close to the bottom of each power rail.

Technical data

General	Type number:	FS-PDC-MBMB-1
	Approvals:	UL, CSA; FM pending
Cables	Type:	HV8-55-c (AWG 8)
	Length:	3 meter
Connectors	2-pole Jackscrew	
	Type connector:	D-TAB-200-JCK
	Type pin:	D-TAB-200-8-S
	Power rating:	55 A
	Temperature:	max. 125 °C (257 °F)

PDC-CPSET

Power distribution cable set Control Processor (24Vdc)

Description

The FS-PDC-CPSET power distribution cable-set transfers power from the 24 Vdc mains bus bar type FS-MB-0001 to the Controller chassis.

The set consists of 2 power cables, one for each Control Processor.

The cables are placed on the appropriate connectors on the backplane (24V-1 and 24V-2 see Figure 506 on page 802).

Figure 506 Position of 24 V connectors on the SM Controller backplane

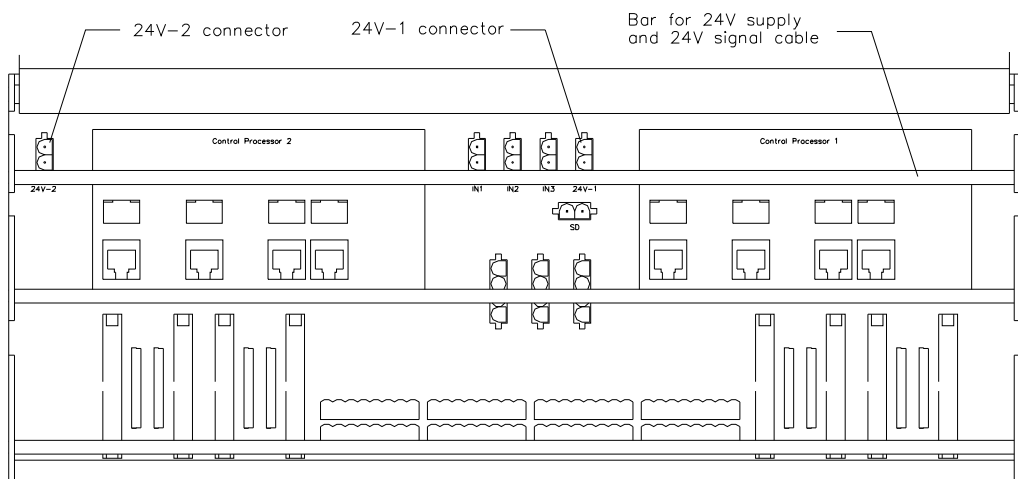

Pin allocation

The back view and pin allocation of the 24V-1 and 24V-2 connectors are:

		24V-1	24V-2
	1	+24V for CP1	+24V for CP2
2	0V for CP1	0V for CP2	

Layout

Figure 507 on page 803 shows the layout of the FS-PDC-CPSET power distribution cable set.

- The FS-PDC-CP24-1 (the short cable in Figure 507 on page 803) connects CP1 with the 24V supply. This cable is placed between the 24V-1 connector on the SM Controller backplane and the 24 Vdc mains bus bar, type FS-MB-0001.
- The FS-PDC-CP24-2 (the long cable in Figure 507 on page 803) connects CP2 with the 24V supply. This cable is placed between the 24V-2 connector on the SM Controller backplane and the 24 Vdc mains bus bar, type FS-MB-0001.

Figure 507 Layout of the FS-PDC-CPSET power distribution cables

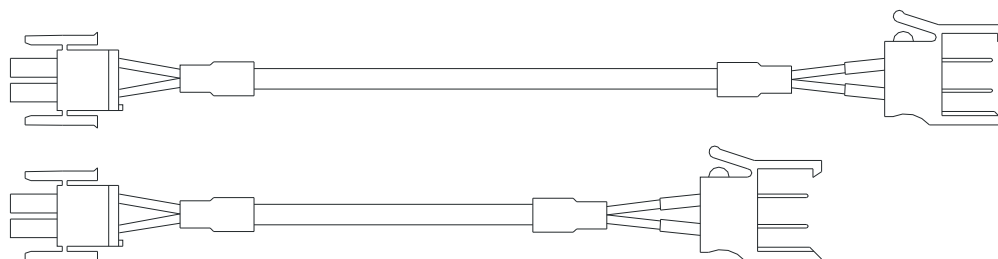

Technical data

General	Type number:	FS-PDC-CPSET
	Approvals:	UL, CSA; FM pending
Cable	Type:	CC600 2 x 2.5 mm ²
	Length FS-PDC-CP24-1:	54 cm (21.26 in)
	Length FS-PDC-CP24-2:	77 cm (30.31 in)
Connectors	Bus bar side:	2 pole Squeeze To Release type: D-TAB-200-STR
	SM Controller side:	2 pole mate-n-lock

PDC-IOSET

Power distribution cable set IO chassis (24Vdc, 48Vdc or 110Vdc)

Description

The FS-PDC-IOSET power distribution cables of the IO chassis transfer 24 Vdc, 48 Vdc or 110Vdc from mains power rails of type FS-MB-0001 to the IO chassis. Figure 508 on page 804 shows the position of the IP1, EP1, EP2, and EP3 connector on the back of an IO chassis.



Attention:

To avoid assembly mistakes the use of color coded labels and/or sleeves is recommended on both the cable sets and the connectors when applied for voltages other than 24Vdc.

Figure 508 Position of the power connectors on an IO backplane

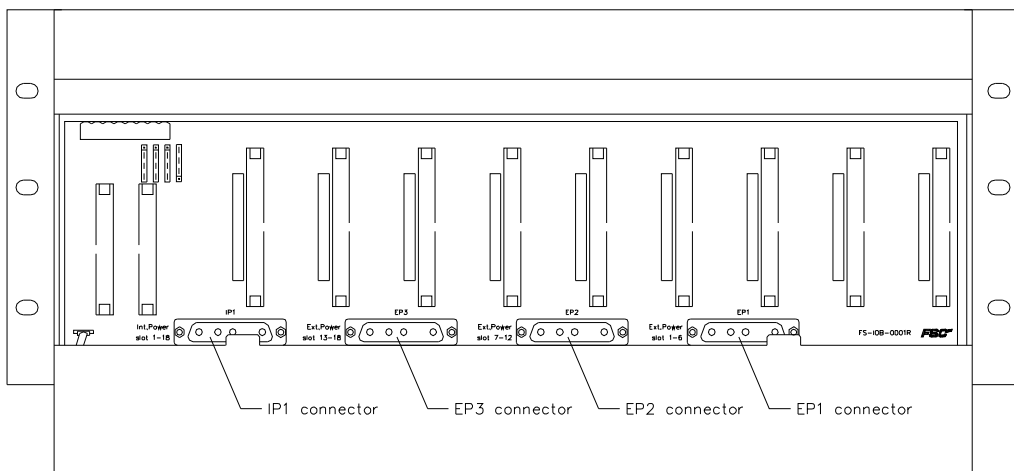

The following module slots are powered by the IO chassis power distribution cables:

IO module slots	Power supply voltage	Cable
1-6	External	FS-PDC-IOEP1a
7-12	External	FS-PDC-IOEP2a
13-18	External	FS-PDC-IOEP3a
All	Internal	FS-PDC-IOIP1a

Pin allocation

The pin allocation of the external power connectors EP1, EP2 and EP3 of a redundant IO chassis are:

Pin	Marking	EP3	EP2	EP1
1	Red (1)	EP slot 13, 15, 17	EP slot 7, 9, 11	EP slot 1, 3, 5
3	Black (1)	0 Volt	0 Volt	0 Volt
4	Black (2)	0 Volt	0 Volt	0 Volt
5	Red (2)	EP slot 14, 16, 18	EP slot 8, 10, 12	EP slot 2, 4, 6

The pin allocation of the internal power connector IP1 of a redundant IO chassis is:

Pin	Marking	IP1	To slot
1	Red (1)	IP	1, 3, 5, 7, 9, 11, 13, 15 and 17
3	Black (1)	0 Volt	
4	Black (2)	0 Volt	
5	Red (2)	IP	2, 4, 6, 8, 10, 12, 14, 16 and 18

The pin allocation of the External Power connectors EP1, EP2 and EP3 of a non-redundant IO chassis are:

Pin	marking	EP3	EP2	EP1
1	Red (1)	EP slot 13, 14, 15	EP slot 7, 8, 9	EP slot 1, 2, 3
3	Black (1)	0 Volt	0 Volt	0 Volt
4	Black (2)	0 Volt	0 Volt	0 Volt
5	Red (2)	EP slot 16, 17, 18	EP slot 10, 11, 12	EP slot 4, 5, 6

The pin allocation of the Internal Power connector IP1 in a non-redundant IO chassis is:

Pin	Marking	IP1
1	Red (1)	IP slot 1-9
3	Black (1)	0 Volt
4	Black (2)	0 Volt
5	Red (2)	IP slot 10-18

Layout

Figure 509 on page 806 shows the layout of the FS-PDC-IOSET power distribution cables.

Figure 509 Layout of the FS-PDC-IOSET power distribution cables

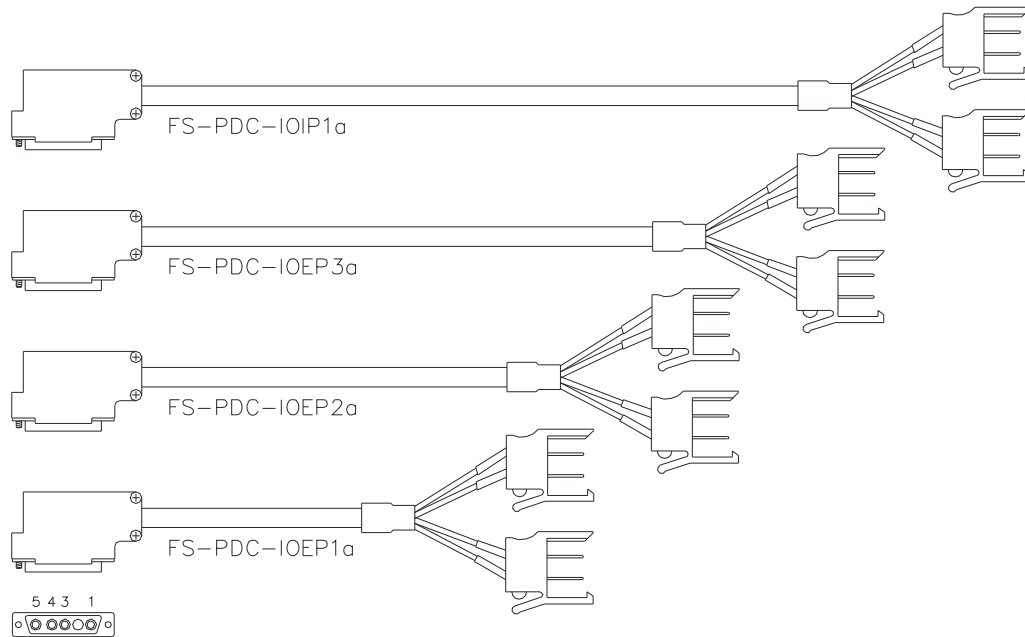

Technical data

General	Type number:	FS-PDC-IOSET	
	Approvals:	UL, CSA; FM pending	
Cable	Type:	CC 600 World 4 × 2.5 mm ²	
	Length:	33 cm (FS-PDC-IOEP1a) 41 cm (FS-PDC-IOEP2a) 49 cm (FS-PDC-IOEP3a) 57 cm (FS-PDC-IOIP1a)	
	Connectors	Bus bar side:	2 pole Squeeze To Release type: D-TAB-200-STR
		IO chassis side:	FM5W5 S (female) housing: low profile, 90°

PDC-CP24

Power distribution cable Control Processor (24Vdc)

Description

The FS-PDC-CP24 power distribution cable of the Control Processor transfers the 24 Vdc from the mains power rails to Controller chassis. Each Control Processor has a separate FS-PDC-CP24 cable.

The cables are placed on the appropriate connectors on the backplane (24V-1 and 24V-2 see Figure 510 on page 807).

Figure 510 Position of 24 V connectors on the SM Controller backplane

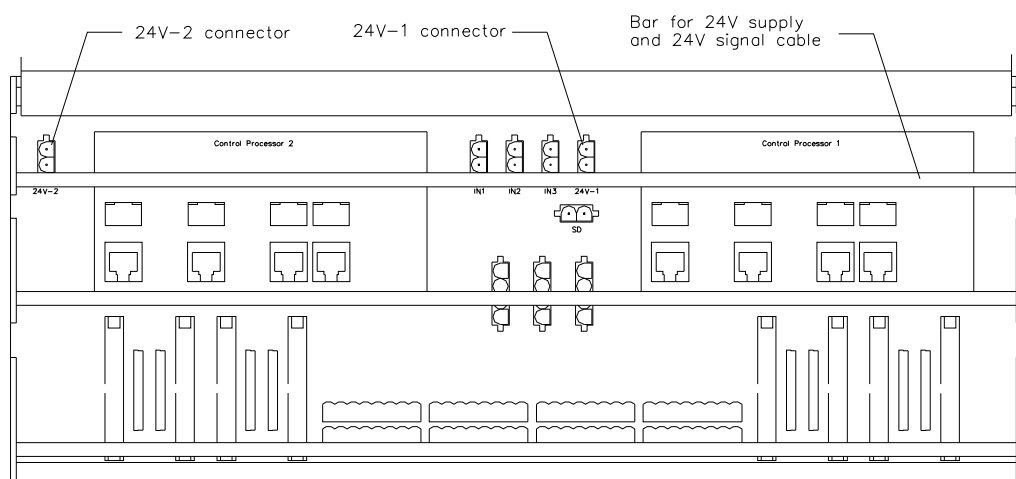

Pin allocation

The back view and pin allocation of the 24V-1 and 24V-2 connectors are:

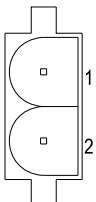
		24V-1	24V-2
	1	+24V for CP1	+24V for CP2
	2	0V for CP1	0V for CP2

Layout

Figure 511 on page 808 shows the layout of the FS-PDC-CP24 power distribution cable.

Figure 511 Layout of the FS-PDC-CP24 power distribution cable

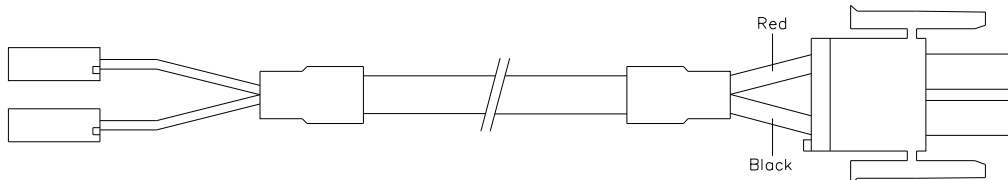

Technical data

General	Type number:	FS-PDC-CP24
	Approvals:	UL, CSA, FM
Cable	Type:	Alphawire 1899AWG/2C ($2 \times 1.3 \text{ mm}^2$)
	Length:	1 m
Connectors	Bus bar side:	Fast-on
	SM Controller side:	2 pole mate-n-lock

PDC-IOxPx

Power distribution cable IO chassis (24Vdc, 48Vdc or 110Vdc)

Description

The FS-PDC-IOxPx power distribution cables of the IO chassis transfer 24 Vdc, 48 Vdc or 110 Vdc from the mains power rails to the IO chassis. Figure 512 on page 809 shows the position of the IP1, EP1, EP2, and EP3 connector on the back of an IO chassis.

Figure 512 Position of the power connectors on an IO backplane

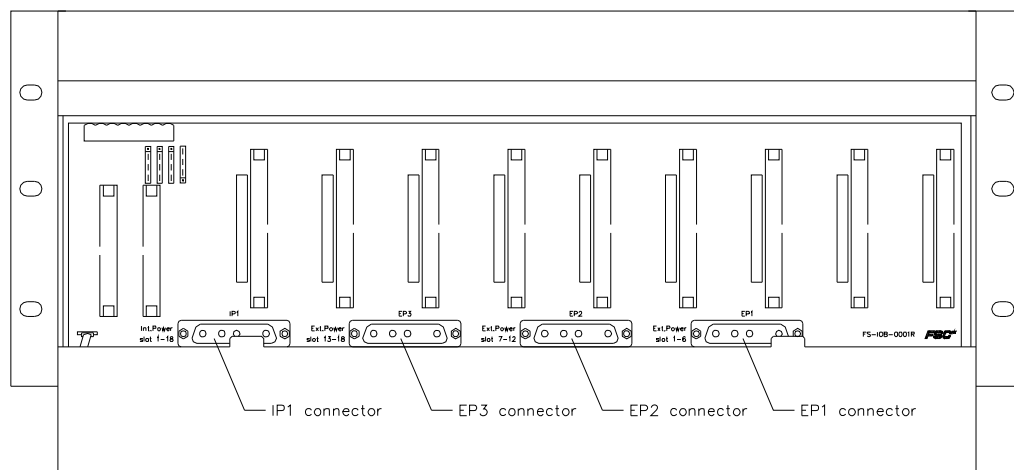

The following module slots are powered by the IO chassis power distribution cables:

IO module slots	Power supply voltage	Cable
1-6	External	FS-PDC-IOEP1
7-12	External	FS-PDC-IOEP2
13-18	External	FS-PDC-IOEP3
All	Internal	FS-PDC-IOIP1

Pin allocation

The pin allocation of the external power connectors EP1, EP2 and EP3 of a redundant IO chassis are:

Pin	Marking	EP3	EP2	EP1
1	Red (1)	EP slot 13, 15, 17	EP slot 7, 9, 11	EP slot 1, 3, 5
3	Black (1)	0 Volt	0 Volt	0 Volt
4	Black (2)	0 Volt	0 Volt	0 Volt
5	Red (2)	EP slot 14, 16, 18	EP slot 8, 10, 12	EP slot 2, 4, 6

The pin allocation of the internal power connector IP1 of a redundant IO chassis is:

Pin	Marking	IP1	To slot
1	Red (1)	IP	1, 3, 5, 7, 9, 11, 13, 15 and 17
3	Black (1)	0 Volt	
4	Black (2)	0 Volt	
5	Red (2)	IP	2, 4, 6, 8, 10, 12, 14, 16 and 18

The pin allocation of the External Power connectors EP1, EP2 and EP3 of a non-redundant IO chassis are:

Pin	marking	EP3	EP2	EP1
1	Red (1)	EP slot 13, 14, 15	EP slot 7, 8, 9	EP slot 1, 2, 3
3	Black (1)	0 Volt	0 Volt	0 Volt
4	Black (2)	0 Volt	0 Volt	0 Volt
5	Red (2)	EP slot 16, 17, 18	EP slot 10, 11, 12	EP slot 4, 5, 6

The pin allocation of the Internal Power connector IP1 in a non-redundant IO chassis is:

Pin	Marking	IP1
1	Red (1)	IP slot 1-9
3	Black (1)	0 Volt
4	Black (2)	0 Volt
5	Red (2)	IP slot 10-18

Layout

Figure 513 on page 811 shows the layout of the FS-PDC-IOxPx power distribution cable.

Figure 513 Layout of the FS-PDC-IOxPx power distribution cables

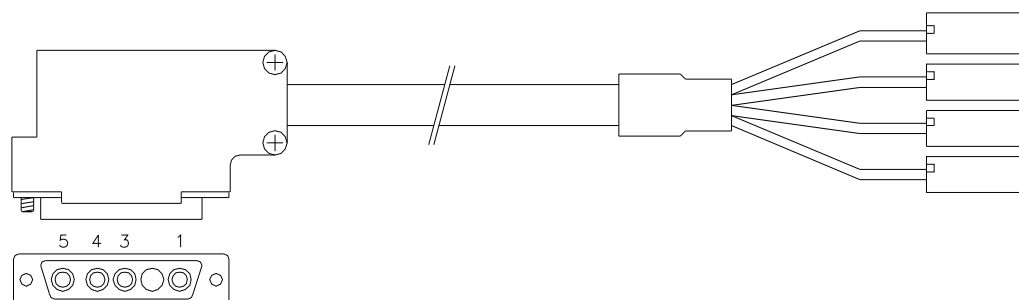

Technical data

General	Type number:	FS-PDC-IOEP1 FS-PDC-IOEP2 FS-PDC-IOEP3 FS-PDC-IOIP1
	Approvals:	UL, CSA, FM
Cable	Type:	CC 600 World 4 × 2.5 mm ²
	Length:	64 cm (IOEP1) 72 cm (IOEP2) 80 cm (IOEP3) 88 cm (IOIP1)
Connectors	Bus bar side:	Fast-on
	IO chassis side:	FM5W5 S (female) housing: low profile, 90°

PDC-MB24-x

Power Distribution Cable (24Vdc)

Description

The FS-PDC-MB24-x power distribution cables transfer the 24Vdc from the main power rail of type FS-MB-0001 to:

- power distribution boards like the FC-PDB-0824 (for details see “PDB-0824” on page 792),
- FTAs equipped with a Weidmuller BVZ 7.62/02F SW power connector, keyed for 24Vdc.

Table 86 on page 812 provides a listing of available cable types and associated lengths.

Table 86 Type and length of FS-PDC-MB24-x power distribution cables

Cable type	length
FS-PDC-MB24-1	145 cm (57.1 in)
FS-PDC-MB24-2	245 cm (96.5 in)
FS-PDC-MB24-3	325 cm (128.0 in)

Layout

Figure 514 on page 812 shows the layout of the FS-PDC-MB24-x power distribution cable.

Figure 514 Layout of the FS-PDC-MB24-x power distribution cable

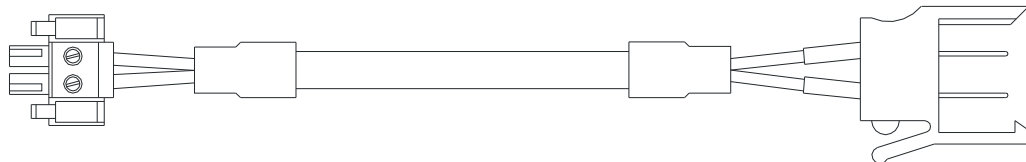

FTA / board connector with 24 Vdc keying

A Weidmuller BVZ 7.62/02F SW cable-connector with 24Vdc keying is used to connect the cable to an FTA or a 24Vdc power distribution board.

Figure 515 on page 813 shows the views, keying and the pin assignment of the Weidmuller BVZ 7.62/02F SW cable-connector.

1. The pin marked “+” is pin 1; connect to +24Vdc wire to the main bus bar
2. The pin marked “-” is pin 2; connect to 0Vdc wire to the main bus bar

Figure 515 FTA/board side connector (Weidmuller BVZ 7.62/02F SW) views and 24 Vdc keying

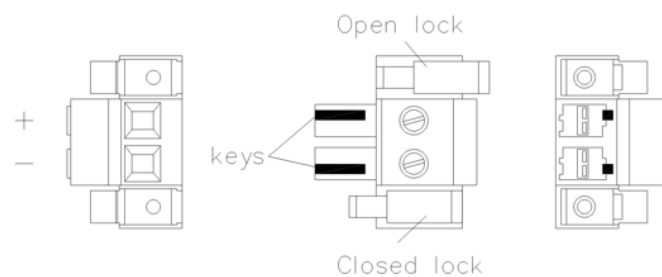

Two (orange) locking slides of the cable-connector in Figure 515 on page 813 keep the cable-connector locked when inserted into the FTA or the power distribution board.

Technical data

General	Type numbers:	FS-PDC-MB24-1 FS-PDC-MB24-2 FS-PDC-MB24-3
	Approvals:	UL, CSA; FM pending
Cable	Type:	CC600 2 x 6mm ²
	Length FS-PDC-MB24-1:	145 cm (57.1 in)
	Length FS-PDC-MB24-2:	245 cm (96.5 in)
	Length FS-PDC-MB24-3:	325 cm (128.0 in)
Connectors	mains power bar side:	2 pole Squeeze To Release type: D-TAB-200-STR
	FTA / board side:	2 pole header with keying Weidmuller: BVZ 7.62/02F SW
	FTA / board keying	Weidmuller: KO BV/SV7.62

PDC-MB24-y

Power Distribution Cable (24Vdc)

Description

The FS-PDC-MB24-y (where “y” stands for 1P, 2P or 3P) power distribution cables transfer the 24Vdc from the main power rail of type FS-MB-0001 to:

- power distribution boards like the FC-PDB-0824P (for details see “PDB-0824P” on page 796),
- FTAs equipped with a Weidmuller SV 7.62HP/02/180F power connector, keyed for 24Vdc.

Table 87 on page 814 provides a listing of available cable types and associated lengths.

Table 87 Type and length of FS-PDC-MB24-y power distribution cables

Cable type	length
FS-PDC-MB24-1P	145 cm (57.1 in)
FS-PDC-MB24-2P	245 cm (96.5 in)
FS-PDC-MB24-3P	325 cm (128.0 in)

Layout

Figure 516 on page 814 shows the layout of the FS-PDC-MB24-y power distribution cable.

Figure 516 Layout of the FS-PDC-MB24-y power distribution cable



FTA / board connector with 24 Vdc keying

A Weidmuller BVZ 7.62HP/02F SN cable-connector with 24Vdc keying is used to connect the cable to an FTA or a 24Vdc power distribution board.

Figure 517 on page 815 shows the views, keying and the pin assignment of the Weidmuller BVZ 7.62HP/02F SN cable-connector.

1. The pin marked “+” is pin 1; connect to +24Vdc wire to the main bus bar
2. The pin marked “-” is pin 2; connect to 0Vdc wire to the main bus bar

Figure 517 FTA/board side connector (Weidmuller BVZ 7.62HP/02F SN) views and 24 Vdc keying

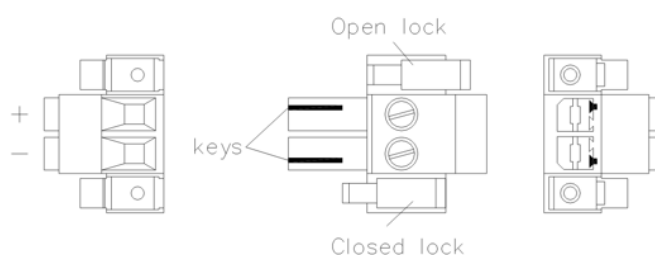

Two (red) locking slides of the cable-connector in Figure 517 on page 815 keep the cable-connector locked when inserted into the FTA or the power distribution board.

Technical data

General	Type numbers:	FS-PDC-MB24-1P FS-PDC-MB24-2P FS-PDC-MB24-3P
	Approvals:	UL, CSA and FM pending
Cable	Type:	CC600 2 x 6mm ²
	Length FS-PDC-MB24-1P:	145 cm (57.1 in)
	Length FS-PDC-MB24-2P:	245 cm (96.5 in)
	Length FS-PDC-MB24-3P:	325 cm (128.0 in)
Connectors	mains power bar side:	2 pole Squeeze To Release type: D-TAB-200-STR
	FTA / board side:	2 pole header with keying Weidmuller: BVZ 7.62HP/02F SN
	FTA / board keying	Weidmuller: BV/SV7.62HP KO

PDC-FTA24

Power Distribution Cable (24Vdc)

Description

The FS-PDC-FTA24 power distribution cables transfer the 24Vdc from the FC-PDB-0824 power distribution board to individual 24Vdc devices inside the cabinet enclosure, such as fan units and FTAs.

(For details on the FC-PDB-0824 power distribution board see “PDB-0824” on page 792.)

The FS-PDC-FTA24 is equipped with a connector on the FC-PDB-0824 side, and no connector on the device side.

Figure 518 on page 816 shows the layout of the FS-PDC-FTA24 power distribution cable.

Figure 518 Layout of the FS-PDC-FTA24 power distribution cable

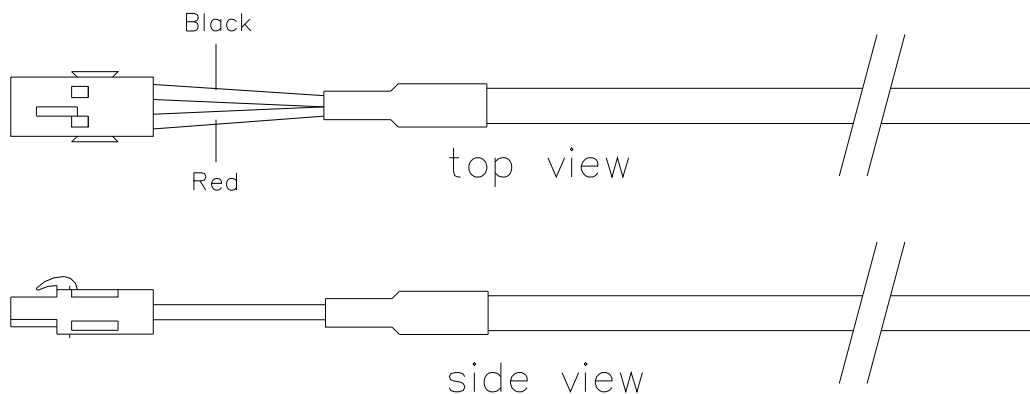

Before connecting the FS-PDC-FTA24 to the device, its wires must be cut to the required length and fitted with a suitable connector for the device. In Figure 518 on page 816:

- The red wire represents the +24Vdc.
- The black wire represents the 0Vdc.