

330400 and 330425 Accelerometer Acceleration Transducers

Datasheet

Cordant™

141638 Rev. AB



Description

These accelerometers are intended for critical machinery applications where casing acceleration measurements are required, such as gear mesh monitoring. The 330400 is designed to address the requirements of American Petroleum Institute Standard 670 for accelerometers. It provides an amplitude range of 50 g peak and a sensitivity of 100 mV/g. The 330425 is identical except it provides a larger amplitude range (75 g peak) and a sensitivity of 25 mV/g.



Most common machine malfunctions (unbalance, misalignment, etc.) occur on the rotor and originate as an increase (or at least a change) in rotor vibration. For any individual casing measurement to be effective for overall machine protection, the system must continually transmit a significant amount of rotor vibration to the machine casing, or mounting location of the transducer.

In addition, be careful to install the accelerometer transducer on the bearing housing or machine casing. Improper installation may decrease the transducer amplitude and frequency response and/or generate false signals that do not represent actual vibration. Refer to the appropriate instruction manuals and Application Notes.

Upon request, Bently Nevada provides engineering services that can identify the appropriate machine housing measurements and installation assistance if needed.



Baker Hughes

Specifications

Parameters are specified from +20 to +30 °C (+68 to +86 °F) and 100 Hz unless otherwise indicated.

Broadband Noise Floor (10 Hz to 15 kHz)	0.098 m/s ² (0.01 g) rms.
---	--------------------------------------



Operation outside the specified limits may result in false readings or loss of machine monitoring.

Electrical

330400

Sensitivity	10.2 mV/m/s ² (100 mV/g) ±5%.
Acceleration range	490 m/s ² (50 g) peak overall acceleration within the 10 Hz to 15 kHz frequency span. Vibration at frequencies above 15 kHz, especially at the transducers resonance will significantly decrease this range.
Amplitude Linearity	±1% to 490 m/s ² (50 g) peak.
Broadband Noise Floor (10 Hz to 15 kHz)	0.039 m/s ² (0.004 g) rms.

330425

Sensitivity	2.5 mV/m/s ² (25 mV/g) ±5%.
Acceleration Range	735 m/s ² (75 g) peak overall acceleration within the 10 Hz to 15 kHz frequency span. Vibration at frequencies above 15 kHz, especially at the transducer's resonance, will significantly decrease this range.
Amplitude Linearity	±1% to 735 m/s ² (75 g) peak.

Both Units

Frequency Response	10 Hz to 15 kHz (600 cpm to 900,000 cpm) ±3dB; 30 Hz to 10 kHz (1800 cpm to 600,000 cpm) ±10%
Temperature Sensitivity	-11% to +3% typical over the operating temperature range.
Transverse Sensitivity	Less than 5% of axial.
Mounted Resonant Frequency	Greater than 30 kHz.
Amplitude of Resonant Peak	20 dB maximum.
Base Strain Sensitivity	
For serial numbers preceded by the letter "G" (including all new sensors)	49 mm/s ² /mstrain (0.005 g/mstrain)

For serial numbers NOT preceded by the letter "G" (shipped prior to April 2004)	980 mm/s ² /mstrain (0.100 g/mstrain) without Mounting Base (API adapter);
	4.9 mm/s ² /mstrain (0.0005 g/mstrain) with Mounting Base (API adapter) supplied with the accelerometer.
<div style="border: 1px solid black; padding: 5px; background-color: #e6f2e6;">  For units bearing serial numbers NOT preceded by the letter "G", Bently Nevada recommends installing with the Mounting Base to minimize base strain sensitivity. </div>	
Maximum cable length	305 metres (1000 ft) with no degradation of signal.
Power requirements	
Input Voltage	-24 ± 0.5 Vdc.
Bias Current	2 mA nominal.
Output Bias Voltage:	-8.5 ± 0.5 Vdc.
Grounding	Case isolated.

Environmental Limits

Operating and storage temperature	-55°C to +121°C (-67°F to +250°F)
Shock Survivability	49,050 m/s ² (5000 g) peak, maximum.
Relative humidity	100% condensing, non-submerged. Case is hermetically sealed.
Magnetic Field Susceptibility	<2.21 mm/s ² /gauss (225 mg/gauss) [50 gauss, 50-60Hz].
IP Rating	Equivalent to an IP 68 (Dust tight and watertight). Please note that this is for the sensor only and does not apply to the cable.
Maximum Use Altitude	2000 meters above sea level
Outdoor Use	Standard installation for these sensors is in a protected enclosure with wiring protected in conduit. Splash boots can be added for additional protection if needed by customer's requirements.

Case Material	316L stainless steel
Weight (no cable)	100 g (3.5 oz), typical
Mounting Angle	Any orientation

Physical

Weight (no cable)	99 g (3.5 oz), typical
Diameter	23 mm (0.93 in).
Height	59 mm (2.3 in), including mounting stud.
Connector	3-pin MIL-C-5015 Receptacle 316L stainless steel
Mounting Surface	32 minch rms.
Mounting Torque	4.1 N·m (3.0 ft·lb).

Compliance and Certifications

FCC

This device complies with part 15 of the FCC Rules. Operation is subject to the following two conditions:

- This device may not cause harmful interference.
- This device must accept any interference received, including interference that may cause undesired operation.

EMC

EMC Directive 2014/30/EU

RoHS

RoHS Directive 2011/65/EU

China RoHS

Cables associated with the product(s) mentioned in this datasheet have an EFUP designation of 15 years, in accordance with SJ/T 11364-2024.



Maritime

ABS Marine Vessels

Offshore Units and Structures

Mobile Offshore Units

ATEX

60079-01

60079-07

60079-11

60079-15

ATEX Directive 2014/34/EU

Hazardous Area Approvals



For the detailed listing of country and product-specific approvals, refer to the [Approvals Quick Reference Guide \(108M1756\)](#).

For additional technical documentation, please log in to bntechsupport.com and access the Bently Nevada Media Library.

cNRTLus

Ex ia IIC T3
AEx ia IIC T3

Class I, Div 1 Groups A, B, C and D
Class II, Groups E, F, and G
Class III

Class I, Div 2, Groups A, B, C, D
Ex ec IIC Gc
Ex tc IIIC Dc
Class I Zone 2, AEx ec IIC Gc
Zone 22, AEx tc IIIC Dc

Install per dwg 167536
 $-55^{\circ}\text{C} \leq \text{Tamb} \leq 121^{\circ}\text{C}$



Requirements for North America:

This sensor may only be powered by a power supply unit with a limited energy electric circuit in accordance with CAN/CSA C22.2 No. 61010-1-12 and ANSI/UL 61010-1, or Class 2 as defined in the Canadian Electrical Code C22.1, Section 16-200 and/or National Electrical Code (NFPA 70), article 725.121.

ATEX/IECEx



Ex ia IIC T3 Ga



Ex ec IIC Gc
Ex tc IIIC Dc

$-55^{\circ}\text{C} \leq \text{Ta} \leq +121^{\circ}\text{C}$

Entity Parameters

Entity Parameters for Zone 0/1 and Zone 2	
Parameters	Values
Ui	28 V
Ii	150 mA
Pi	0.84 W
Ci	10.8 nF
Li	0 μH

Hazardous Area Conditions of Safe Use

ATEX/IECEx

Zone 0/1:

Equipment must be connected to equipment, which meets the abovelisted entity parameters.

- The cables type A or B (in compliance with EN 60079-25) must respect the cable parameters listed with the entity parameters.



Special Notes

- This equipment is intrinsically safe and can be used in potentially explosive atmospheres.
- The intrinsically safe apparatus shall only be connected to an associated intrinsically safe apparatus. The association shall comply with the requirements of EN 60079-25 standard.
- Operating ambient temperature range: -55 °C
Tamb +121 °C



Requirements for North America:

This sensor may only be powered by a power supply unit with a limited energy electric circuit in accordance with CAN/CSA C22.2 No. 61010-1-12 and ANSI/UL 61010-1, or Class 2 as defined in the Canadian Electrical Code C22.1, Section 16-200 and/or National Electrical Code (NFPA 70), article 725.121.

Zone 2:

The supply electrical parameters shall not exceed the values mentioned in the tables above.



Special Notes

- The equipment is safe when connected to an associated source, containing a reliable material limiting current and voltage meeting the entity parameters.
- Operating ambient temperature
-55°C to +121°C
- The mating part of the connector shall provide IP54 ingress protection or better according to requirements of IEC 60079-0 and IEC 60079-7 or IEC 60079-15.
- Provisions shall be made for ensuring that the rated voltage and current are not exceeded while in service.
- Transient protection shall be provided that is set at a level not exceeding 140 % of the peak rated voltage value at the supply terminals to the equipment.



Requirements for North America:

This sensor may only be powered by a power supply unit with a limited energy electric circuit in accordance with CAN/CSA C22.2 No. 61010-1-12 and ANSI/UL 61010-1, or Class 2 as defined in the Canadian Electrical Code C22.1, Section 16-200 and/or National Electrical Code (NFPA 70), article 725.121.

Ordering Information



For the detailed listing of country and product-specific approvals, refer to the [Approvals Quick Reference Guide \(108M1756\)](#).

For additional technical documentation, please log in to bntechsupport.com and access the Bently Nevada Media Library.

330400 Accelerometer 330425 Accelerometer

Part Number-AA-BB

A: Mounting Thread Option

0 1	¼-28 UNF integral stud
0 2	M8 X 1 integral stud

B: Agency Approval Option

0 0	None
0 5	Multiple approvals (CSA, ATEX, IECEx,)

Interconnect Cables

Part Number-AA

A:	Cable Length Option in feet
	For the cables listed below, order in increments of 1.0 ft (305 mm).

Examples:

- 1 5** = 15 ft (4.57 m)
- 2 0** = 20 ft (6.10 m)

The following are standard lengths

Feet	Metres (approx.)
------	------------------

6	1.8
8	2.4
10	3.0
12	3.6
15	4.5
17	5.0
20	6.0
25	7.6
50	15.2
99	30.0



Non-standard/custom lengths can also be ordered at additional cost.

Cable Part Numbers

130539	3-conductor shielded 18 AWG (1.0 mm ²) cable with 3-socket plug and fluorosilicone elastomer boot at one end, terminal lugs at the other end. Minimum length of 2.0 ft (0.6 m), maximum length of 99 ft (30 m). A manual is available to assist with installation of this cable (part number 133080-01).
16925	3-conductor shielded 22 AWG (0.5 mm ²) cable with 3-socket plug at one end, terminal lugs at the other end. Minimum length of 2.0 ft (0.6 m), maximum length of 99 ft (30 m).

16710	3-conductor shielded 22 AWG (0.5 mm ²) armored cable with 3-socket plug at one end, terminal lugs at the other end. Minimum length of 3.0 ft (0.9 m), maximum length of 99 ft (30 m).
-------	---

Accessories

127088	330400 and 330425 Accelerometer User Guide
00531080	Mating connector for 330400 and 330425 Accelerometers.
37439-01	For use with serial numbers NOT preceded with the letter "G". Mounting Base, ¼-28 to ¼-28. Reduces base strain sensitivity.
37439-02	For use with serial numbers NOT preceded with the letter "G". Mounting Base, M8X1 to M8X1. Reduces base strain sensitivity.
43217	Accelerometer Mounting Kit used with extension part number 108576-01 and O-ring part number 04290422 to allow room for the 330400 or 330425 accelerometer. (See separate datasheet, document 141630.)

Graphs and Figures

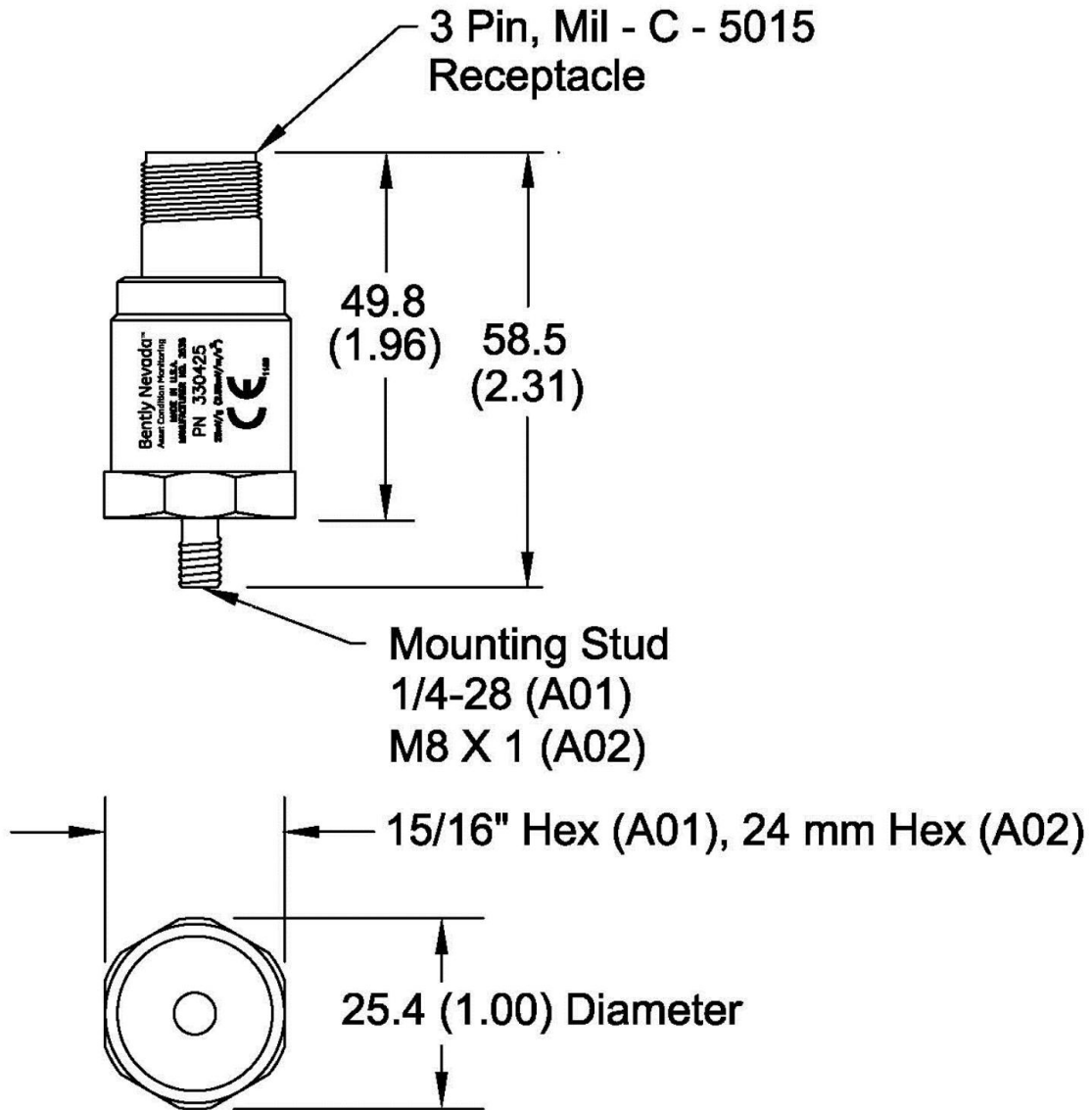

Figure 1: Acceleration Transducer Dimensional Drawing

Dimensions are in millimetres (inches)

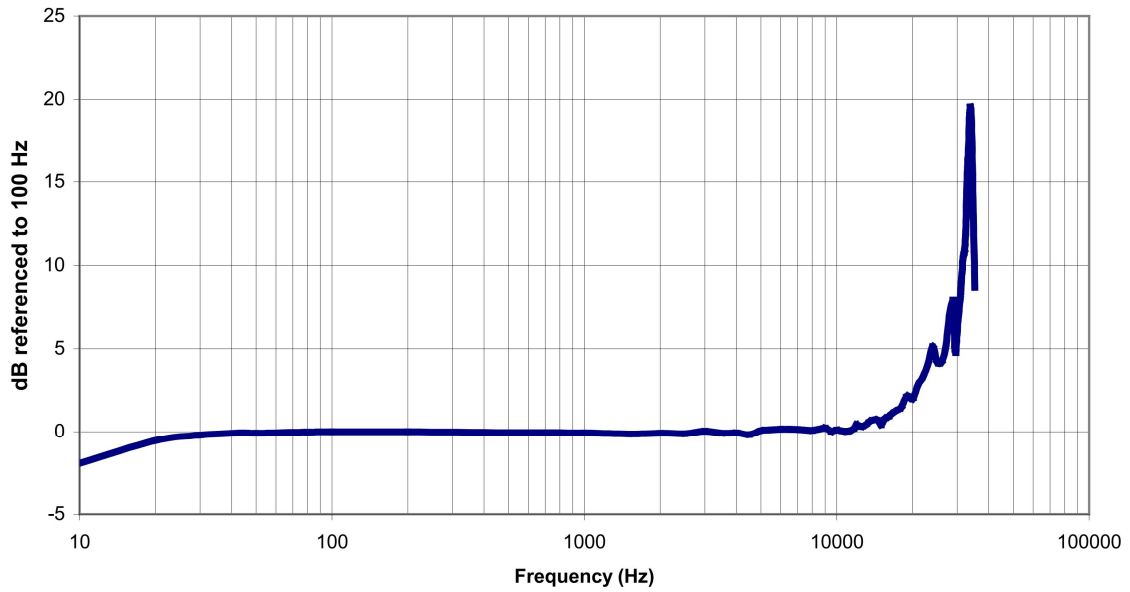

Figure 2: Typical Amplitude Response

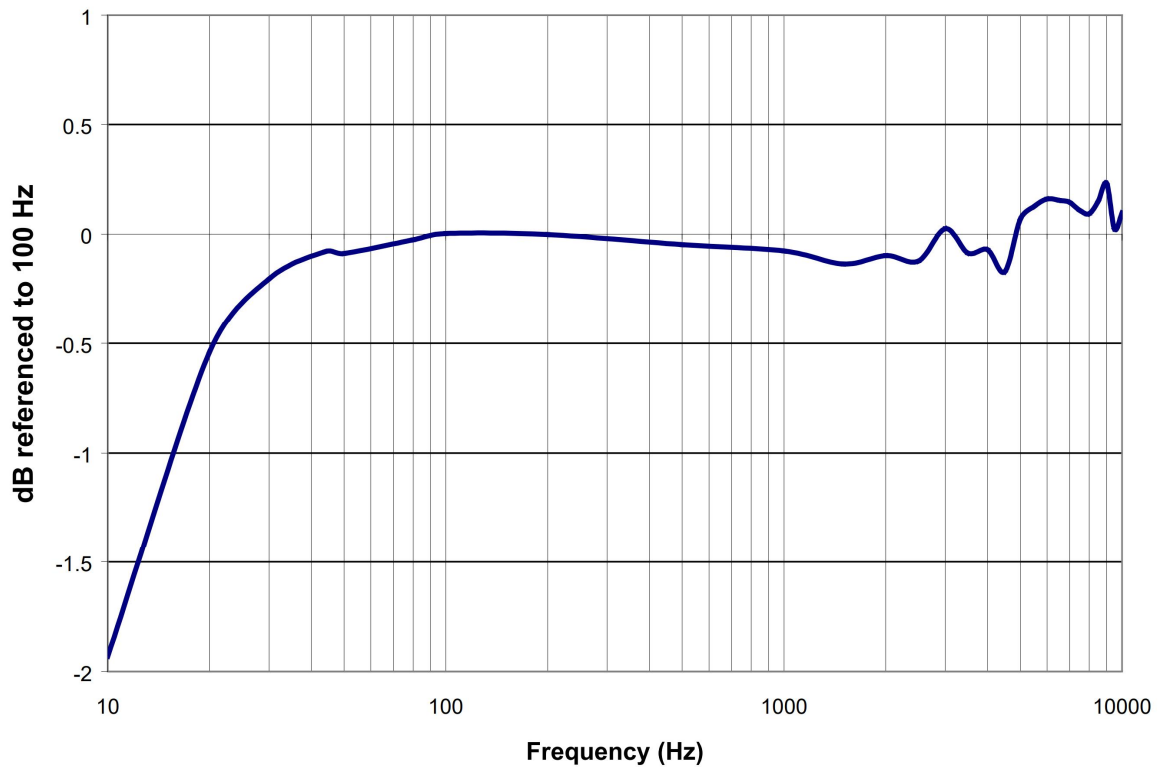

Figure 3: 10 - 10,000 Hz Typical Amplitude Response Detail

Copyright 2025 Baker Hughes Company. All rights reserved.

Bently Nevada, a Baker Hughes Company
1631 Bently Parkway South, Minden, Nevada USA 89423
<https://bntechsupport.com>