



# 1771-N Series I/O to 1756 ControlLogix I/O (Cat 1492-CONACAB020N\* and 1492-CONACAB050N\*)

## I. Description of the Existing 1771-N Series I/O Wiring System

The 1771-N Series High Resolution Isolated Analog I/O modules were designed to be used with 1771 Remote Termination Panels (RTPs) and connected by a 6ft or 15ft cable, as follows.  
 Catalog Number: 1771-NC6 (6 ft) or 1771-NC15 (15 ft) cables.  
 Variations of remote termination panels are used, depending on the type of module used. These are:

Catalog Number	Description
1771-RTP1	has cold junction compensation for thermocouples
1771-RTP3	incorporates resistors and fuses; used primarily for 4 - 20mA inputs when using $\pm 5V$ inputs (Uses 5mm x 20mm fast acting 1/4A fuses such as Bussmann GMA-1/4, 250V / 250mA)
1771-RTP4	a general use block with straight-thru wiring that can be used for all applications except thermocouples
1771-RT41	a 4-channel block with cold junction compensation for thermocouples
1771-RT44	a general use 4-channel block with straight-thru wiring that can be used for all applications except thermocouples
RTP4 and RT44 can be used with thermocouples if a method of odd junction compensation is provided at the interface of thermocouple and copper wires within the system	

The remote termination panels are designed for mounting on standard DIN 1 or DIN 3 mounting rails.

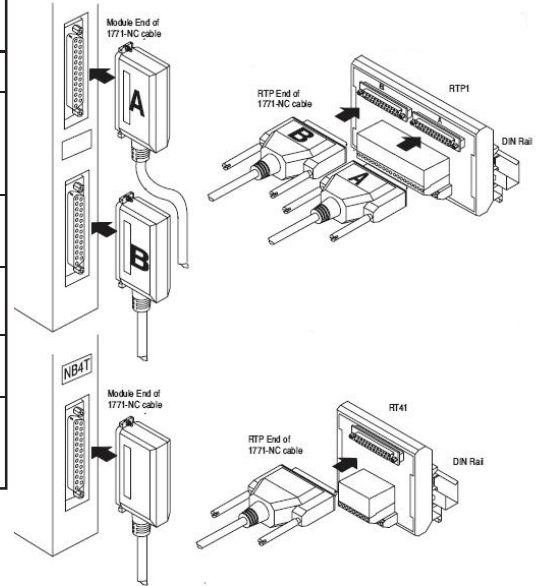

Module	Channel 1	Channel 2	Channel 3	Channel 4	Channel 5	Channel 6	Channel 7	Channel 8
1771-NIS	4 - 20mA	4 - 20mA	4 - 20mA	4 - 20mA	4 - 20mA	4 - 20mA	4 - 20mA	4 - 20mA
1771-NIV	$\pm 5V (\pm 20mA)$	$\pm 5V (\pm 20mA)$	$\pm 5V (\pm 20mA)$	$\pm 5V (\pm 20mA)$	$\pm 5V (\pm 20mA)$	$\pm 5V (\pm 20mA)$	$\pm 5V (\pm 20mA)$	$\pm 5V (\pm 20mA)$
1771-NIV1	$\pm 10V$	$\pm 10V$	$\pm 10V$	$\pm 10V$	$\pm 10V$	$\pm 10V$	$\pm 10V$	$\pm 10V$
1771-NIVR	$\pm 5V (\pm 20mA)$	$\pm 5V (\pm 20mA)$	$\pm 5V (\pm 20mA)$	$\pm 5V (\pm 20mA)$	RTD	RTD	RTD	RTD
1771-NIVT	$\pm 5V (\pm 20mA)$	$\pm 5V (\pm 20mA)$	$\pm 5V (\pm 20mA)$	$\pm 5V (\pm 20mA)$	$\pm 100mV / TC$	$\pm 100mV / TC$	$\pm 100mV / TC$	$\pm 100mV / TC$
1771-NR	RTD	RTD	RTD	RTD	RTD	RTD	RTD	RTD
1771-NT1	$\pm 100mV / TC$	$\pm 100mV / TC$	$\pm 100mV / TC$	$\pm 100mV / TC$	$\pm 100mV / TC$	$\pm 100mV / TC$	$\pm 100mV / TC$	$\pm 100mV / TC$
1771-NT2	-5 / +55mV / TC	-5 / +55mV / TC	-5 / +55mV / TC	-5 / +55mV / TC	-5 / +55mV / TC	-5 / +55mV / TC	-5 / +55mV / TC	-5 / +55mV / TC
1771-NOC	0 - 25mA out	0 - 25mA out	0 - 25mA out	0 - 25mA out	0 - 25mA out	0 - 25mA out	0 - 25mA out	0 - 25mA out
1771-NOV	$\pm 10V$ out	$\pm 10V$ out	$\pm 10V$ out	$\pm 10V$ out	$\pm 10V$ out	$\pm 10V$ out	$\pm 10V$ out	$\pm 10V$ out

## II. Description of the Conversion Solution

This conversion from the 1771-N Series I/O to a 1756 ControlLogix I/O is accomplished simply by replacing the (2) existing cables A & B with (1 or 2) of the following new 1492 cables. Each of these cables has a connector on one end that attaches directly to the existing 1771 RTP. On the other end of the new cable is (1) 1756 Removable Terminal Block (RTB) for connection to the new 1756 ControlLogix I/O Module. The I/O signals are routed from the existing 1771 RTP through the 1492 cables to the appropriate terminals on the 1756 I/O module, per the Wiring Diagrams in this Installation Manual. This allows the conversion to be completed without the removal of any field wires from the existing 1771-RTP.

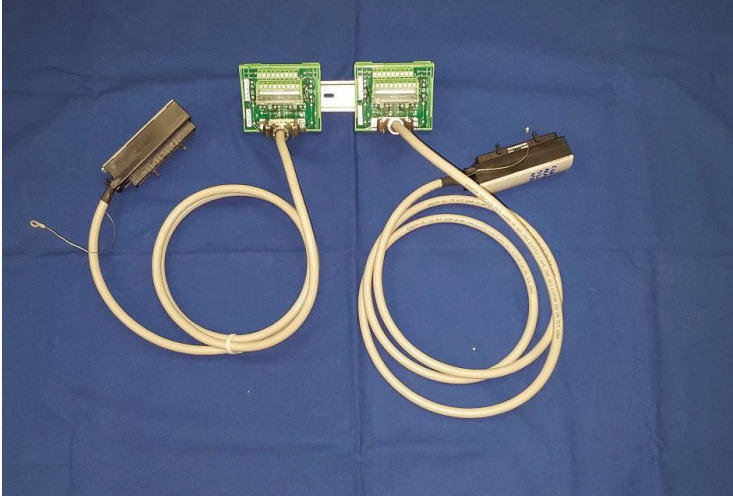

Cable Catalog Numbers:  
 1492-CONACAB020N5  
 1492-CONACAB020N6

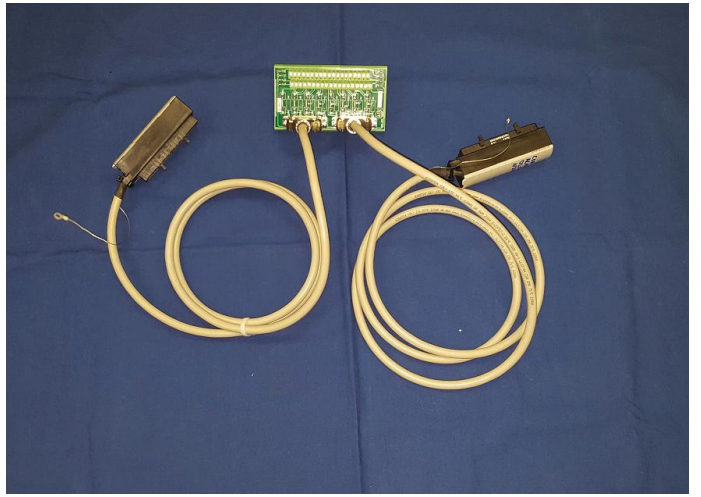

Cable Catalog Numbers:  
 1492-CONACAB020N1 1492-CONACAB020N34  
 1492-CONACAB020N2 1492-CONACAB020N44  
 1492-CONACAB020N3 1492-CONACAB020N54  
 1492-CONACAB020N4 1492-CONACAB020N74  
 1492-CONACAB020N5  
 1492-CONACAB020N7

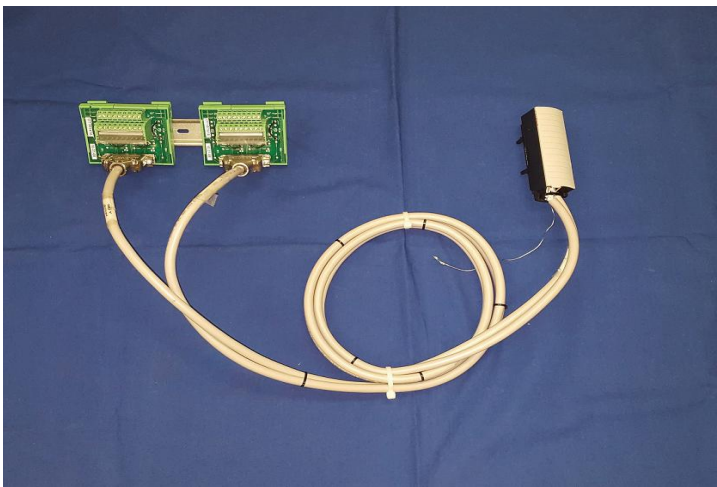

Cable Catalog Numbers:  
 1492-CONACAB020N68

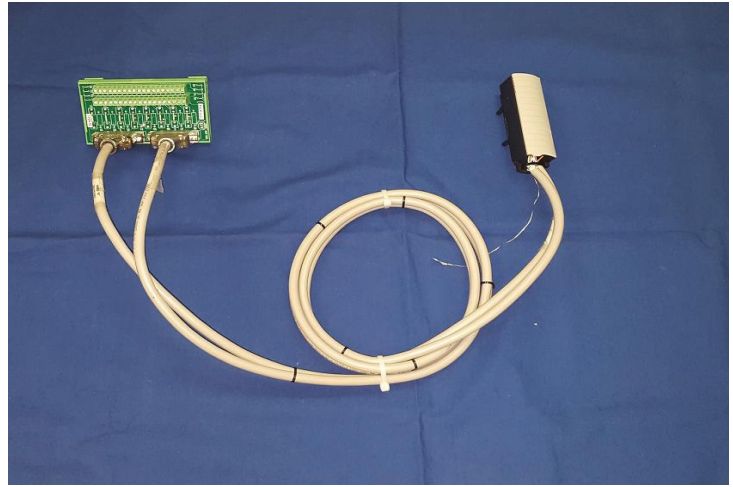

Cable Catalog Number:  
 1492-CONACAB020N8  
 1492-CONACAB020N88  
 1492-CONACAB020N38  
 1492-CONACAB020N78  
 1492-CONACAB020N48  
 1492-CONACAB020N18

### III. Compatibility for I/O Modules

I/O Description	Convert From: <sup>①</sup>		Convert To: <sup>①</sup>		Cable Description	Conversion Cable Catalog Number <sup>④</sup> <sup>③</sup>		Wiring Diagram Page #
	1771 Module	Qty.	1756 Module	Qty.		Cable "A"	Cable "B"	
Standard 1771-N High Resolution I/O	1771-NOC	1	1756-OF8I	1	Current (8 Ch)	1492-CONACAB020N88		4
	1771-NOC	1	1756-OF8	1	Current (8 Ch)	1492-CONACAB020N8		5
	1771-NOC	1	1756-OF6CI	2	Current (4/4 Ch)	1492-CONACAB020N1	1492-CONACAB020N1	6
	1771-NIS	1	1756-IF8I	1	Current (8 Ch)	1492-CONACAB020N38		7
	1771-NIS	1	1756-IF6CIS	2	Current (4/4 Ch)	1492-CONACAB020N2	1492-CONACAB020N2	8
	1771-NIV	1	1756-IF8I	1	Current (8 Ch)	1492-CONACAB020N38		9
	1771-NIV	1	1756-IF6I	2	Current (4/4 Ch)	1492-CONACAB020N3	1492-CONACAB020N3	10
	1771-NIV	1	1756-IF8I	1	Voltage (8 Ch)	1492-CONACAB020N78		11
	1771-NIV	1	1756-IF6I	2	Voltage (4/4 Ch)	1492-CONACAB020N7	1492-CONACAB020N7	12
	1771-NIV	1	1756-IF6I	2	Current (A - 4 Ch) / Voltage (B - 4 Ch)	1492-CONACAB020N3	1492-CONACAB020N7	13
	1771-NIV	1	1756-IF6I	2	Voltage (A - 4 Ch) / Current (B - 4 Ch)	1492-CONACAB020N7	1492-CONACAB020N3	14
	1771-NR	1	1756-IRT8I	1	RTD (8 Ch)	1492-CONACAB020N48		15
	1771-NR	1	1756-IR6I	2	RTD (4/4 Ch)	1492-CONACAB020N4	1492-CONACAB020N4	16
	② 1771-NT1 <sup>⑤</sup>	1	1756-IRT8I	1	Thermocouple (8 Ch)	1492-CONACAB020N68		17
	② 1771-NT1	1	1756-IT6I	2	Thermocouple (4/4 Ch)	1492-CONACAB020N5	1492-CONACAB020N5	18
	1771-NOV	1	1756-OF8I	1	Voltage (8 Ch)	1492-CONACAB020N18		19
	1771-NOV	1	1756-OF6VI	2	Voltage (4/4 Ch)	1492-CONACAB020N1	1492-CONACAB020N1	20
	1771-NIV1	1	1756-IF8I	1	Voltage (8 Ch)	1492-CONACAB020N78		21
	1771-NIV1	1	1756-IF6I	2	Voltage (4/4 Ch)	1492-CONACAB020N7	1492-CONACAB020N7	22
	② 1771-NT2 <sup>⑤</sup>	1	1756-IRT8I	1	Thermocouple (8 Ch)	1492-CONACAB020N68		17
② 1771-NT2	1	1756-IT6I2	2	Thermocouple (4/4 Ch)	1492-CONACAB020N6	1492-CONACAB020N6	23	
Combination 1771-N High Resolution I/O	1771-NIVR	1	1756-IRT8I	1	RTD (4 Ch)	-	1492-CONACAB020N44	24
			1756-IF8I	1	Voltage (4 Ch)	1492-CONACAB020N74	-	
	1771-NIVR	1	1756-IR6I	1	RTD (4 Ch)	-	1492-CONACAB020N4	25
			1756-IF6I	1	Voltage (4 Ch)	1492-CONACAB020N7	-	
	1771-NIVR	1	1756-IRT8I	1	RTD (4 Ch)	-	1492-CONACAB020N44	26
			1756-IF8I	1	Current (4 Ch)	1492-CONACAB020N34	-	
	1771-NIVR	1	1756-IR6I	1	RTD (4 Ch)	-	1492-CONACAB020N4	27
			1756-IF6I	1	Current (4 Ch)	1492-CONACAB020N3	-	
	1771-NIVT	1	1756-IRT8I	1	Thermocouple (4 Ch)	-	1492-CONACAB020N54	28
			1756-IF8I	1	Voltage (4 Ch)	1492-CONACAB020N74	-	
	1771-NIVT	1	1756-IT6I	1	Thermocouple (4 Ch)	-	1492-CONACAB020N5	29
			1756-IF6I	1	Voltage (4 Ch)	1492-CONACAB020N7	-	
	1771-NIVT	1	1756-IRT8I	1	Thermocouple (4 Ch)	-	1492-CONACAB020N54	30
1756-IF8I			1	Current (4 Ch)	1492-CONACAB020N34	-		
1771-NIVT	1	1756-IT6I	1	Thermocouple (4 Ch)	-	1492-CONACAB020N5	31	
		1756-IF6I	1	Current (4 Ch)	1492-CONACAB020N3	-		

Foot Notes:

- ① To understand any issues concerning I/O module compatibility refer to the Installation Manuals for the specific I/O modules involved.
- ② This conversion solution requires replacement of the existing (1) 1771-RTP1 interface module with (2) 1771-RT41 interface modules. Each 1771-RTP1 module has a cold junction compensation thermocouple attached to the interface module.
- ③ These catalog numbers are for a 2.0M cable length. A 5.0M cable is also available. Change the 3 numerals in the middle of the catalog number from "020" to "050" (Example: 1492-CONACAB020N1 becomes 1492-CONACAB050N1).
- ④ These cables have a maximum operating voltage of 30VDC, 2A maximum per pin, 12A maximum per cable.
- ⑤ Wiring diagram for these are identical.



**WARNING**

There are several key application considerations and system specifications (bottom of drawing) when using these components (conversion module, cable and input module). Read and understand these considerations before installation.

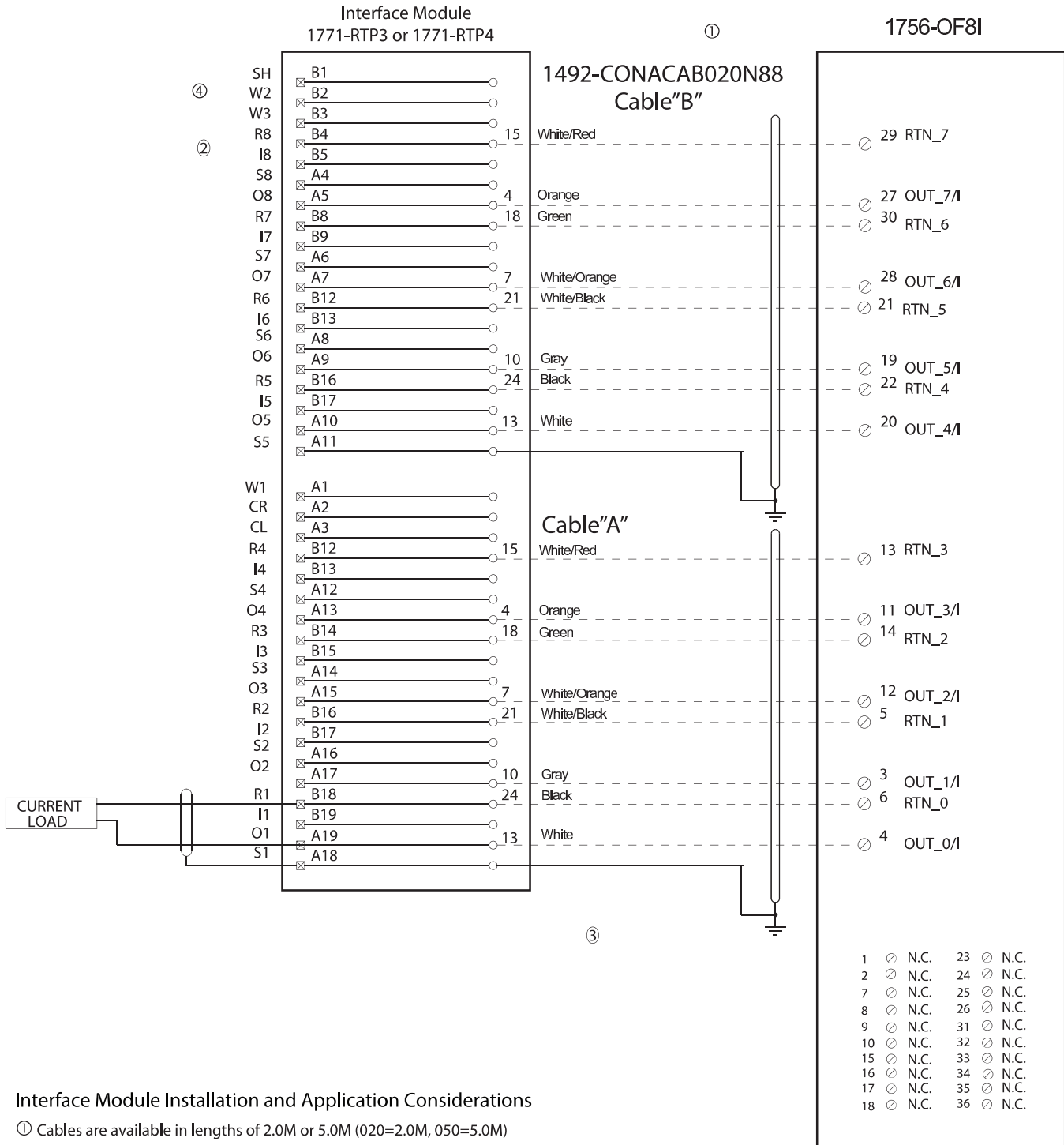

**Interface Module Installation and Application Considerations**

- ① Cables are available in lengths of 2.0M or 5.0M (020=2.0M, 050=5.0M)
- ② Terminals starting with A are the lower row of terminals, B terminals are the upper row.
- ③ Follow your PLC Analog User Manual for proper shield grounding instructions.
- ④ Terminals w1, w2, w3, are spares used for field wire convenience. NOTE: This is only true for module RTP3 and RTP4. The Bul. 1492 cable does not connect to these terminals.

[Reference Doc: DIR 10002306650]

## V. Wiring Diagrams

### Conversion: 1771-NOC (1) To 1756-OF8 (1) (Current, Non-Isolated) Using Existing 1771-RTP3 or RTP4 Interface Module



#### WARNING

There are several key application considerations and system specifications (bottom of drawing) when using these components (conversion module, cable and input module). Read and understand these considerations before installation.

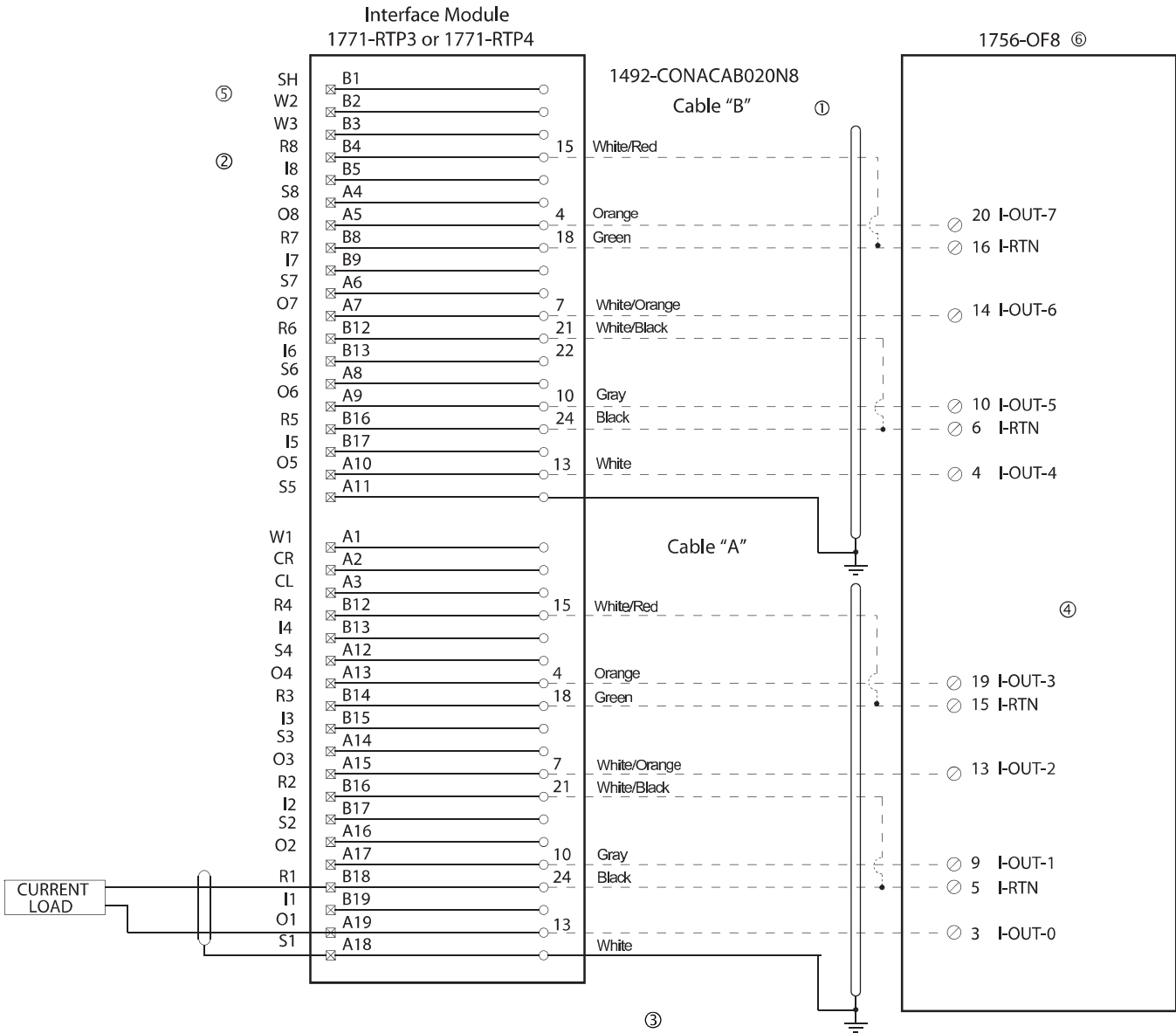

#### Conversion Module Installation and Application Considerations

- ① Cables are available in lengths of 2.0M or 5.0M (020=2.0M, 050=5.0M)
- ② Terminals starting with A are the lower row of terminals, B terminals are the upper row.
- ③ Follow your PLC Analog User Manual for proper shield grounding instructions.
- ④ RTN terminals are internally connected on the 1756-OF8.
- ⑤ Terminals w1, w2, w3, are spares used for field wire convenience. NOTE: This is only true for module RTP3 and RTP4. The Bul. 1492 cable does not connect to these terminals.
- ⑥ The 1771-NOC module provides channel to channel isolation, the 1756-OF8 does not. A conversion from 1771-NOC to an isolated 1756-OF8 is available.

[Reference Doc: 41171-079]

V. Wiring Diagrams

Conversion: 1771-NOC (1) To 1756-OF6CI (2) (Current, Isolated)  
Using Existing 1771-RTP3 or RTP4 Interface Module



There are several key application considerations and system specifications (bottom of drawing) when using these components (conversion module, cable and input module). Read and understand these considerations before installation.

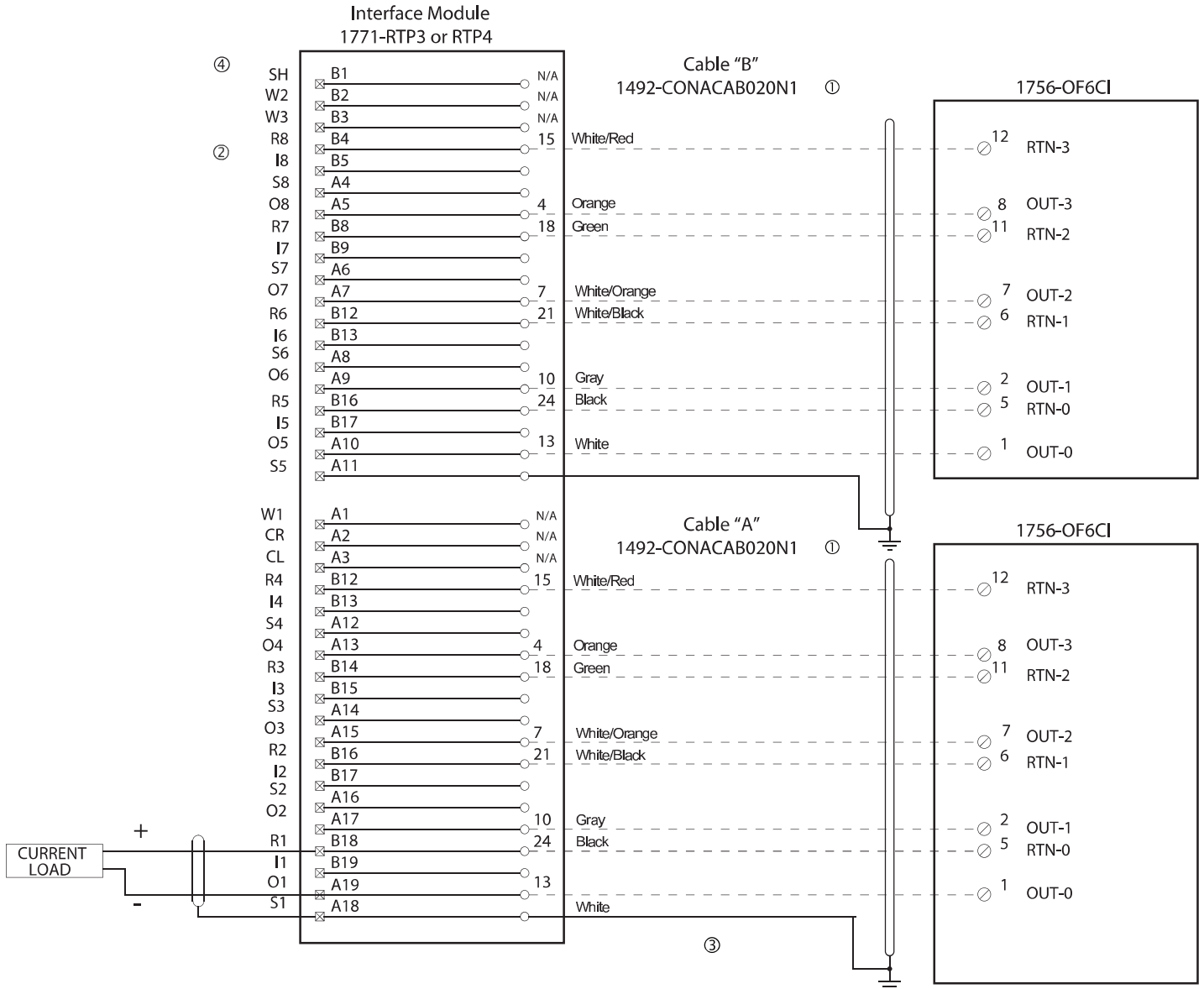

Conversion Module Installation and Application Considerations

- ① Cables are available in lengths of 2.0M or 5.0M (020=2.0M, 050=5.0M)
- ② Terminals starting with A are the lower row of terminals, B terminals are the upper row.
- ③ Follow your PLC Analog User Manual for proper shield grounding instructions.
- ④ Terminals w1, w2, w3, are spares used for field wire convenience. NOTE: This is only true for modules RTP3 and RTP4. The Bul. 1492 cable does not connect to these terminals.

[Reference Doc: 41171-072]



**WARNING**

There are several key application considerations and system specifications (bottom of drawing) when using these components (conversion module, cable and input module). Read and understand these considerations before installation.

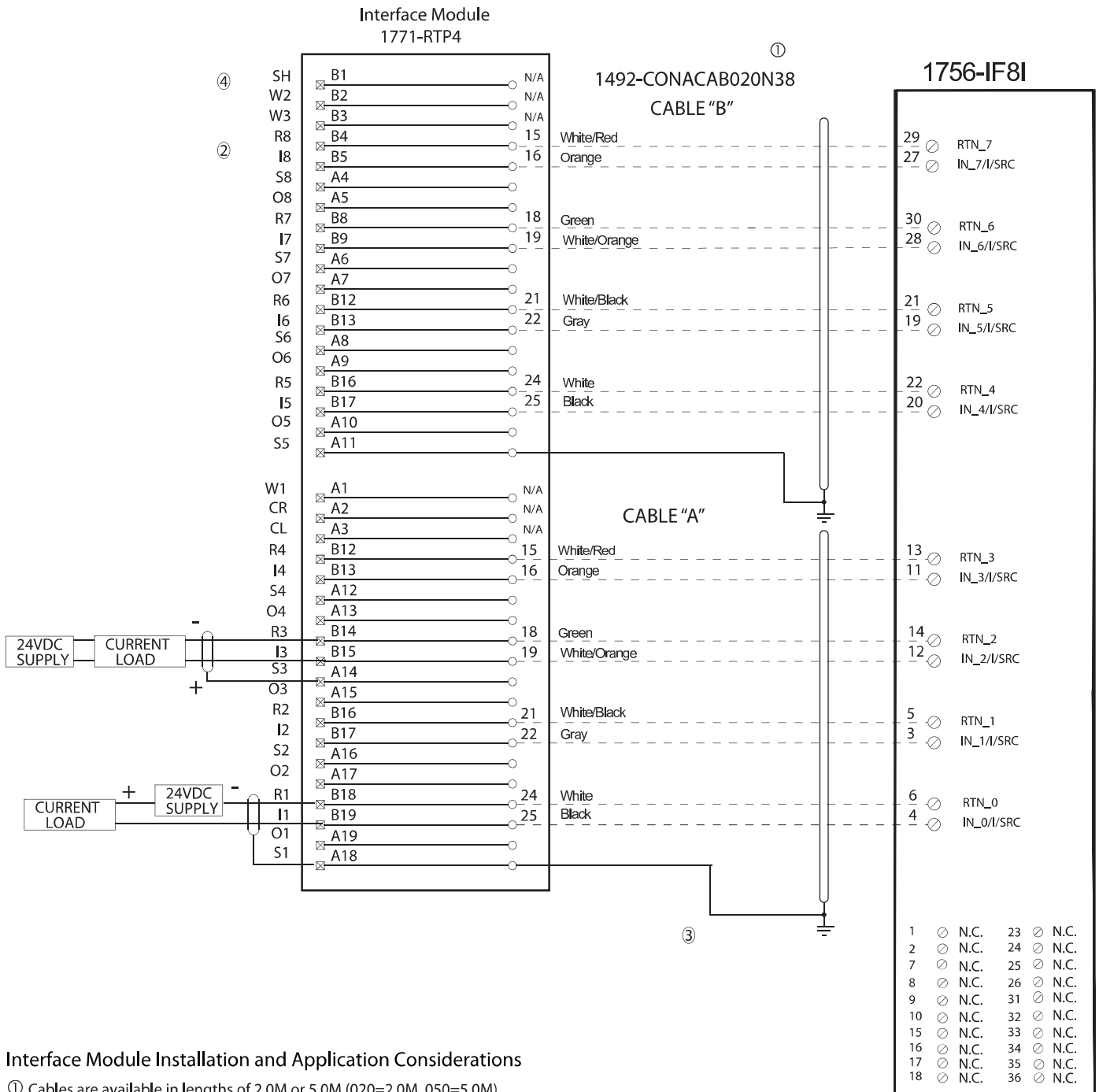

**Interface Module Installation and Application Considerations**

- ① Cables are available in lengths of 2.0M or 5.0M (020=2.0M, 050=5.0M)
- ② Terminals starting with A are the lower row of terminals, B terminals are the upper row.
- ③ Follow your PLC Analog User Manual for proper shield grounding instructions.
- ④ Terminals w1, w2, w3, are spares used for field wire convenience. NOTE: This is only true for module RTP4. The Bul. 1492 cable does not connect to these terminals.

[Reference Doc: 10002306457]

## V. Wiring Diagrams

### Conversion: 1771-NIS (1) To 1756-IF6CIS (2) (Current) Using Existing 1771-RTP4 Interface Module



#### WARNING

There are several key application considerations and system specifications (bottom of drawing) when using these components (conversion module, cable and input module). Read and understand these considerations before installation.

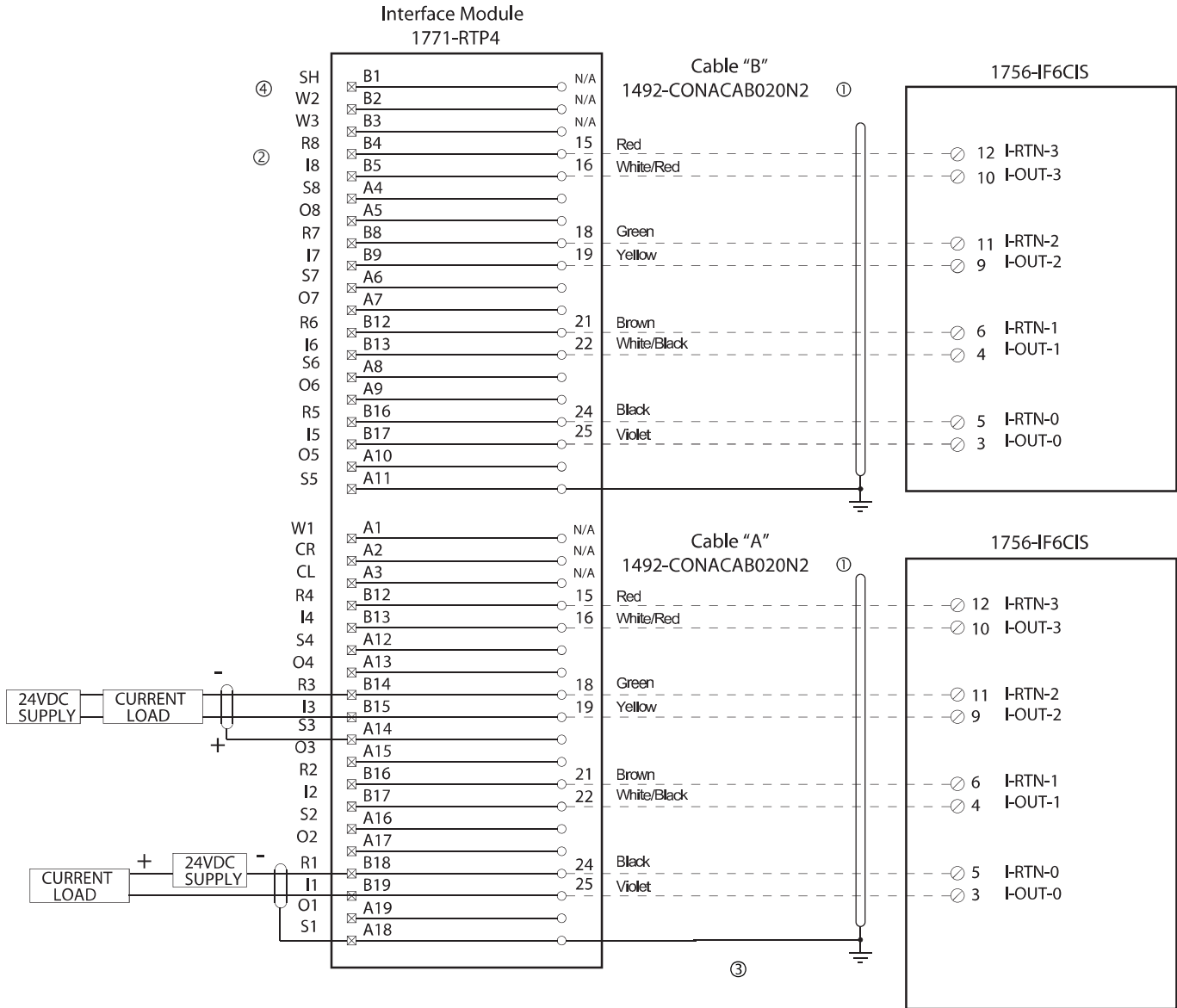

#### Conversion Module Installation and Application Considerations

- ① Cables are available in lengths of 2.0M or 5.0M (020=2.0M, 050=5.0M)
- ② Terminals starting with A are the lower row of terminals, B terminals are the upper row.
- ③ Follow your PLC Analog User Manual for proper shield grounding instructions.
- ④ Terminals w1, w2, w3, are spares used for field wire convenience. NOTE: This is only true for module RTP4. The Bul. 1492 cable does not connect to these terminals.

[Reference Doc: 41171-073]



**WARNING**

There are several key application considerations and system specifications (bottom of drawing) when using these components (conversion module, cable and input module). Read and understand these considerations before installation.

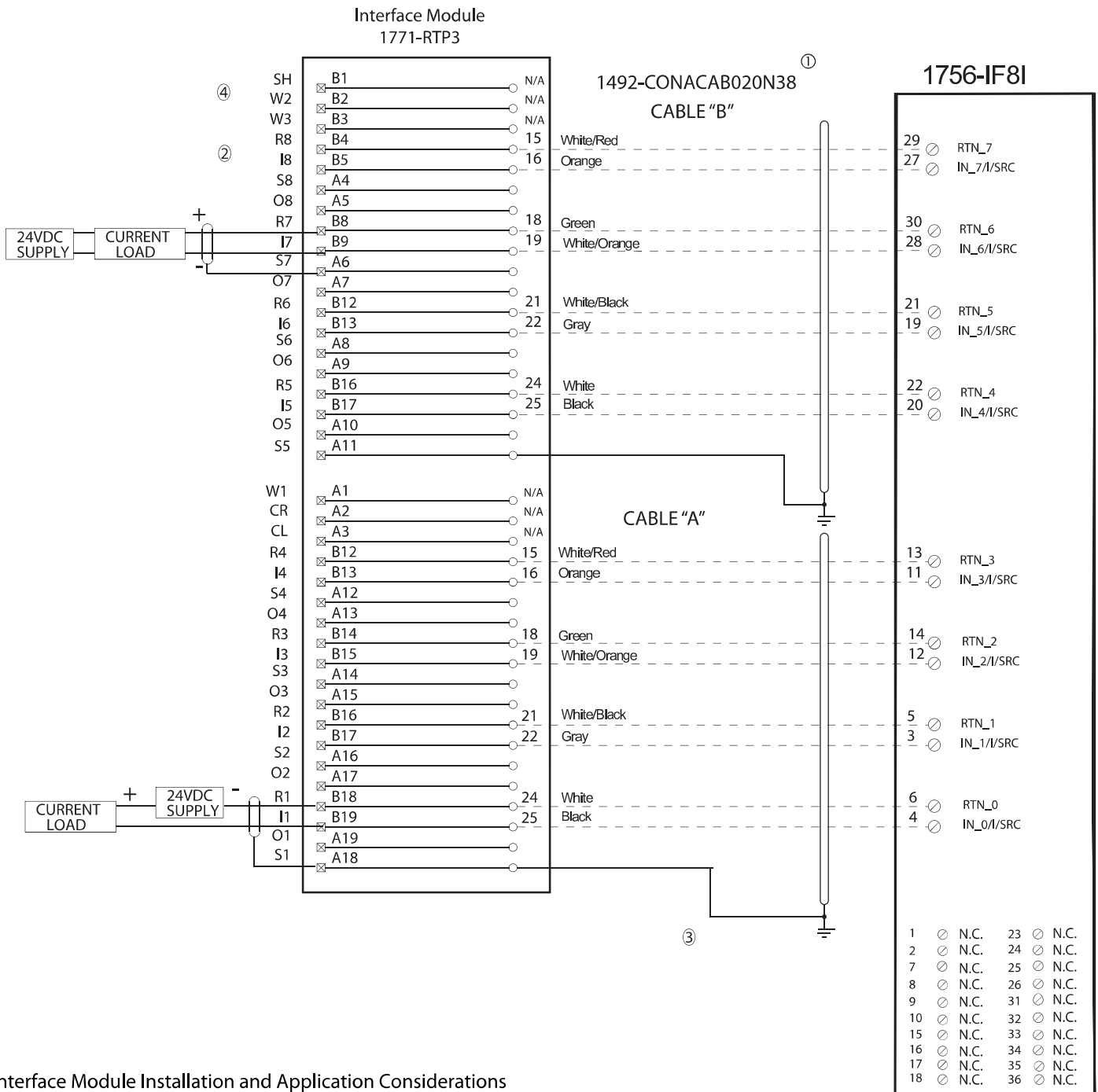

**Interface Module Installation and Application Considerations**

- ① Cables are available in lengths of 2.0M or 5.0M (020=2.0M, 050=5.0M)
- ② Terminals starting with A are the lower row of terminals, B terminals are the upper row.
- ③ Follow your PLC Analog User Manual for proper shield grounding instructions.
- ④ Terminals w1, w2, w3, are spares used for field wire convenience. NOTE: This is only true for module RTP3 and RTP4. The Bul. 1492 cable does not connect to these terminals.

Conversion: 1771-NIV (1) To 1756-IF6I (2) (Current)  
Using Existing 1771-RTP3 Interface Module



**WARNING**

There are several key application considerations and system specifications (bottom of drawing) when using these components (conversion module, cable and input module). Read and understand these considerations before installation.

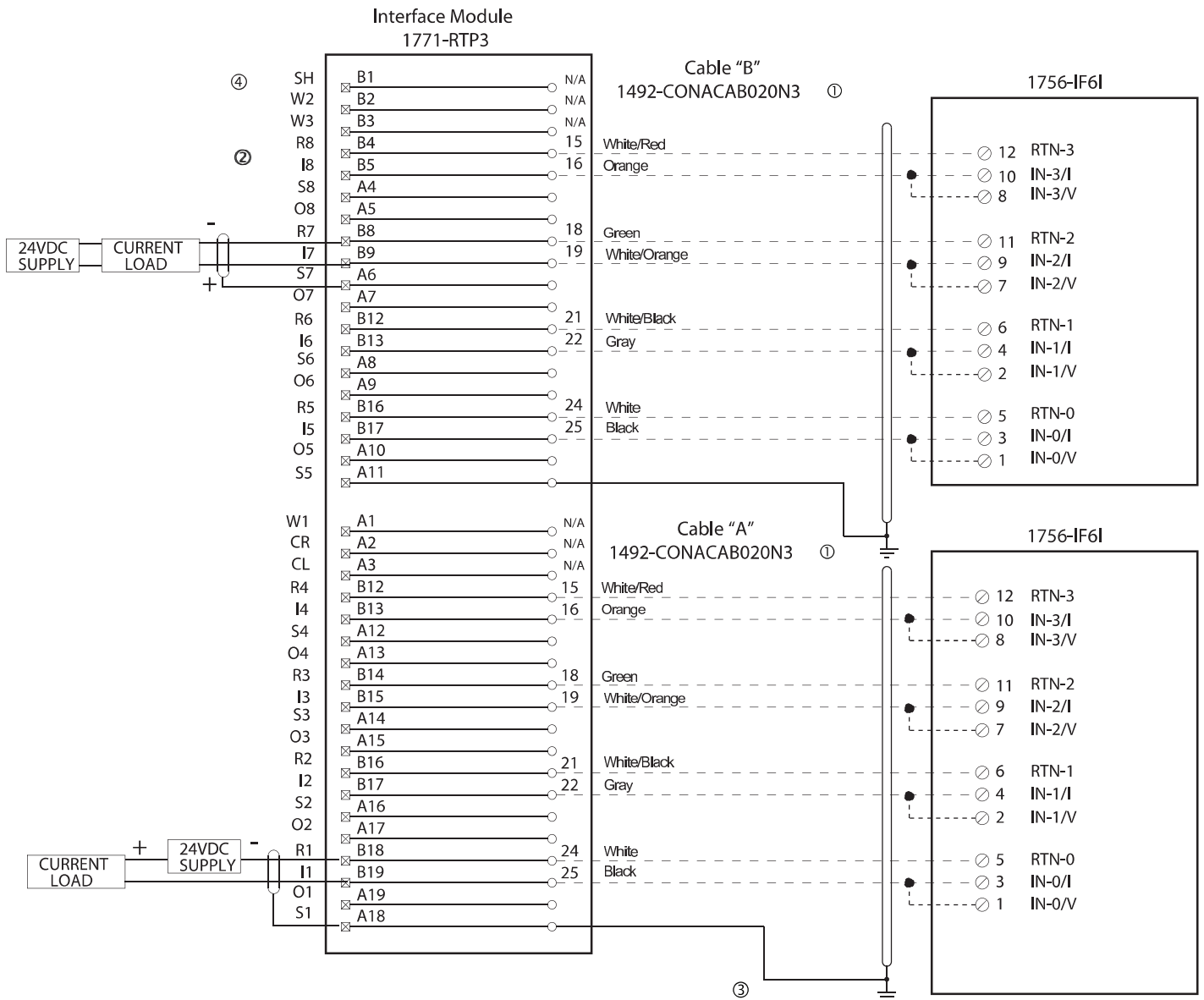

**Interface Module Installation and Application Considerations**

- ① Cables are available in lengths of 2.0M or 5.0M (020=2.0M, 050=5.0M)
- ② Terminals starting with A are the lower row of terminals, B terminals are the upper row.
- ③ Follow your PLC Analog User Manual for proper shield grounding instructions.
- ④ Terminals w1, w2, w3, are spares used for field wire convenience. NOTE: This is only true for module RTP3 and RTP4. The Bul. 1492 cable does not connect to these terminals.

## V. Wiring Diagrams

### Conversion: 1771-NIV (1) To 1756-IF8I (1) (Voltage) Using Existing 1771-RTP4 Interface Module



#### WARNING

There are several key application considerations and system specifications (bottom of drawing) when using these components (conversion module, cable and input module). Read and understand these considerations before installation.

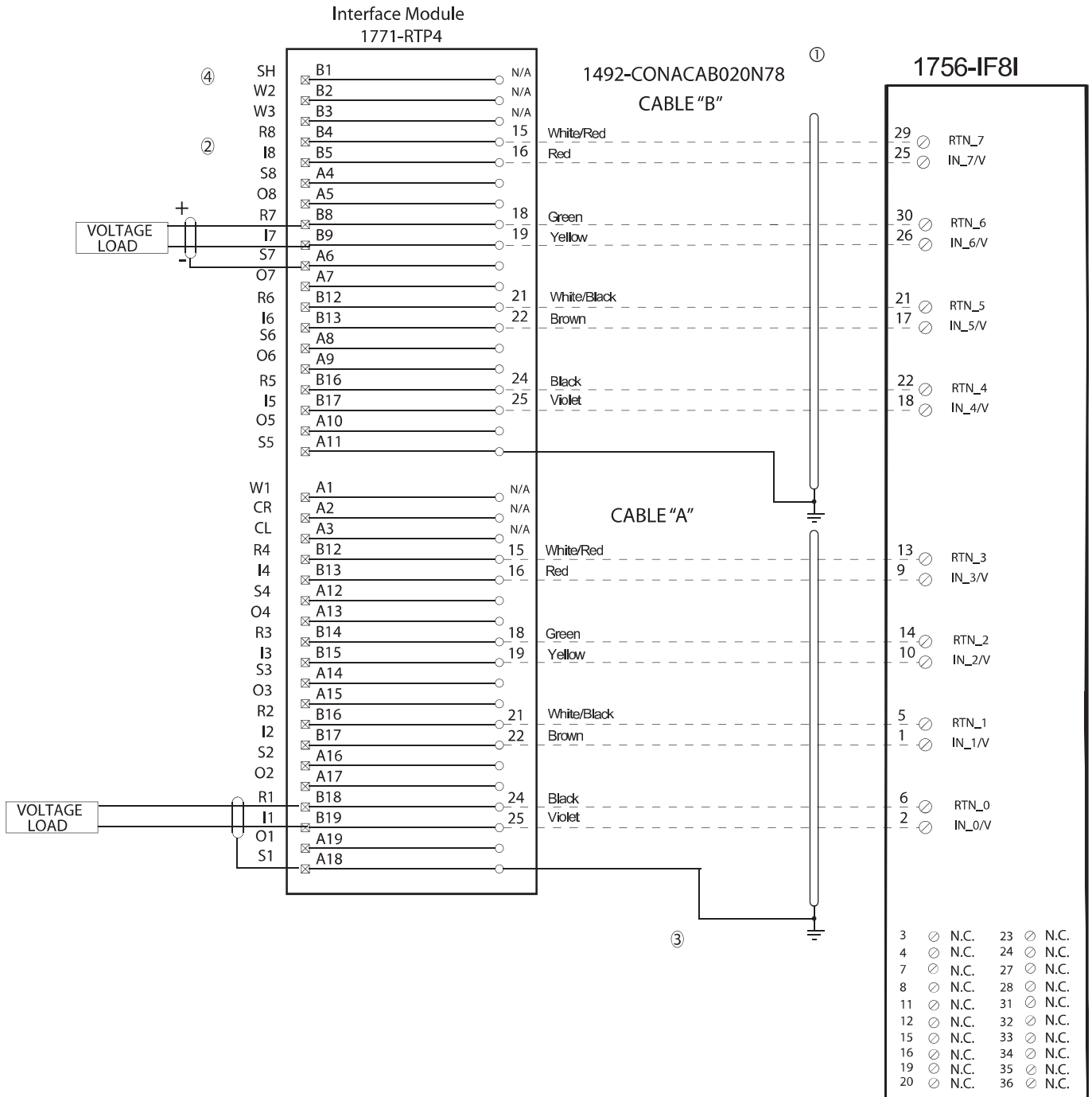

#### Interface Module Installation and Application Considerations

- ① Cables are available in lengths of 2.0M or 5.0M (020=2.0M, 050=5.0M)
- ② Terminals starting with A are the lower row of terminals, B terminals are the upper row.
- ③ Follow your PLC Analog User Manual for proper shield grounding instructions.
- ④ Terminals w1, w2, w3, are spares used for field wire convenience. NOTE: This is only true for module RTP3 and RTP4. The Bul. 1492 cable does not connect to these terminals.

## V. Wiring Diagrams

### Conversion: 1771-NIV (1) To 1756-IF6I (2) (Voltage) Using Existing 1771-RTP4 Interface Module



#### WARNING

There are several key application considerations and system specifications (bottom of drawing) when using these components (conversion module, cable and input module). Read and understand these considerations before installation.

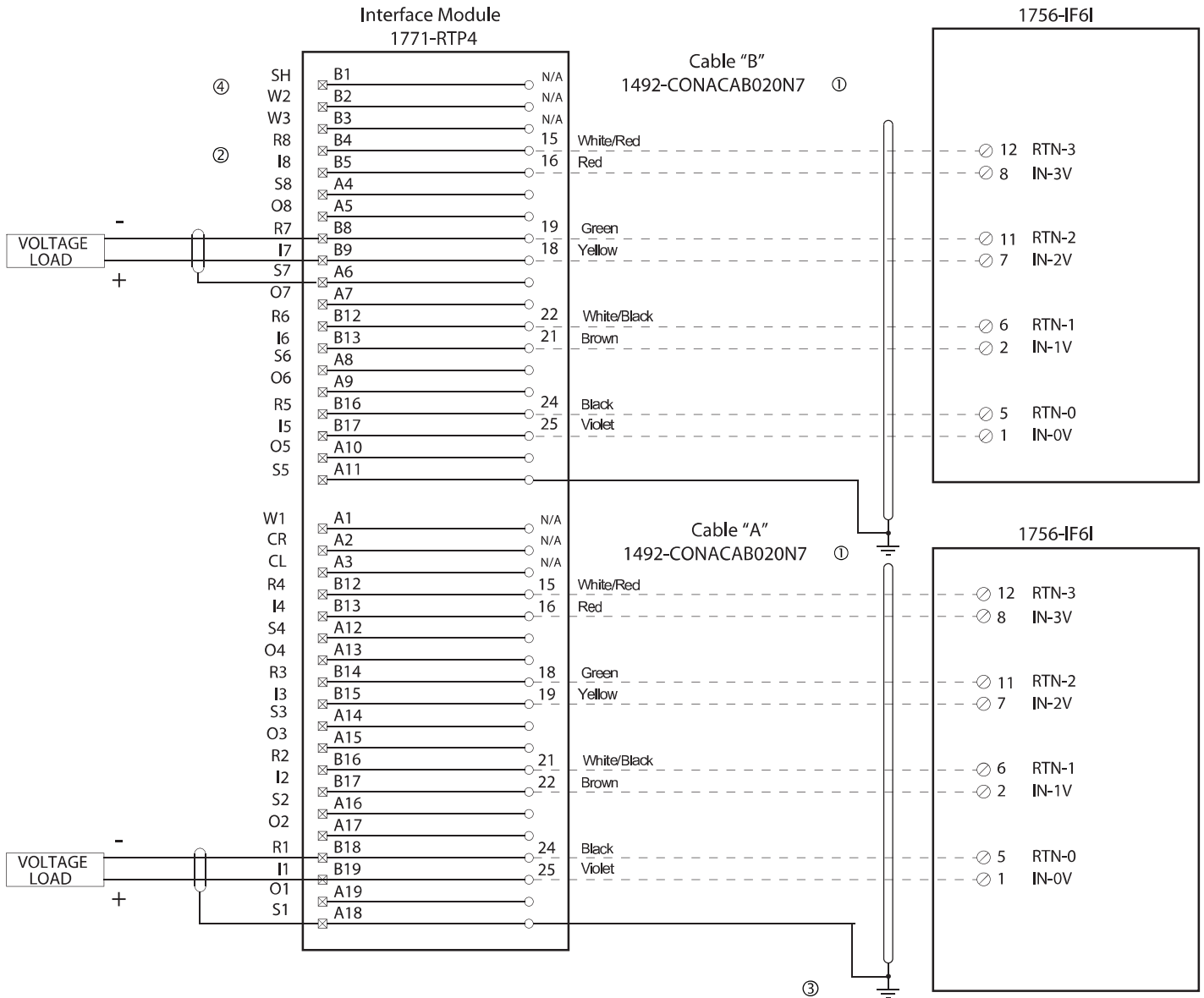

#### Interface Module Installation and Application Considerations

- ① Cables are available in lengths of 2.0M or 5.0M (020=2.0M, 050=5.0M)
- ② Terminals starting with A are the lower row of terminals, B terminals are the upper row.
- ③ Follow your PLC Analog User Manual for proper shield grounding instructions.
- ④ Terminals w1, w2, w3, are spares used for field wire convenience. NOTE: This is only true for module RTP3 and RTP4. The Bul. 1492 cable does not connect to these terminals.

## V. Wiring Diagrams

### Conversion: 1771-NIV (1) To 1756-IF6I (1) (Voltage) And 1756-IF6I (1) (Current) Using Existing 1771-RTP4 Interface Module



#### WARNING

There are several key application considerations and system specifications (bottom of drawing) when using these components (conversion module, cable and input module). Read and understand these considerations before installation.

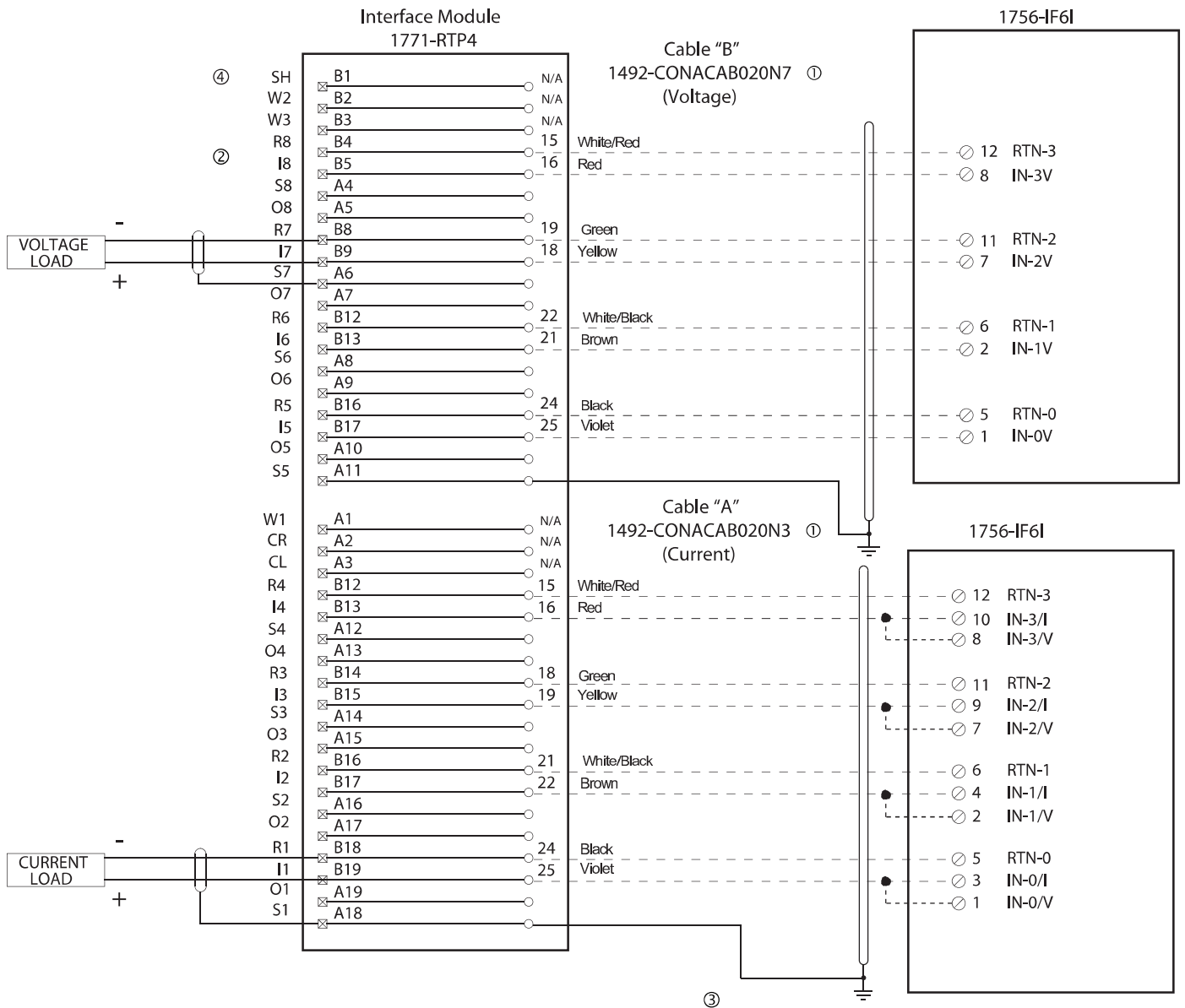

#### Interface Module Installation and Application Considerations

- ① Cables are available in lengths of 2.0M or 5.0M (020=2.0M, 050=5.0M)
- ② Terminals starting with A are the lower row of terminals, B terminals are the upper row.
- ③ Follow your PLC Analog User Manual for proper shield grounding instructions.
- ④ Terminals w1, w2, w3, are spares used for field wire convenience. NOTE: This is only true for module RTP3 and RTP4. The Bul. 1492 cable does not connect to these terminals.

Conversion: 1771-NIV (1) To  
1756-IF6I (1) (Current) And 1756-IF6I (1) (Voltage)  
Using Existing 1771-RTP4 Interface Module



**WARNING**

There are several key application considerations and system specifications (bottom of drawing) when using these components (conversion module, cable and input module). Read and understand these considerations before installation.

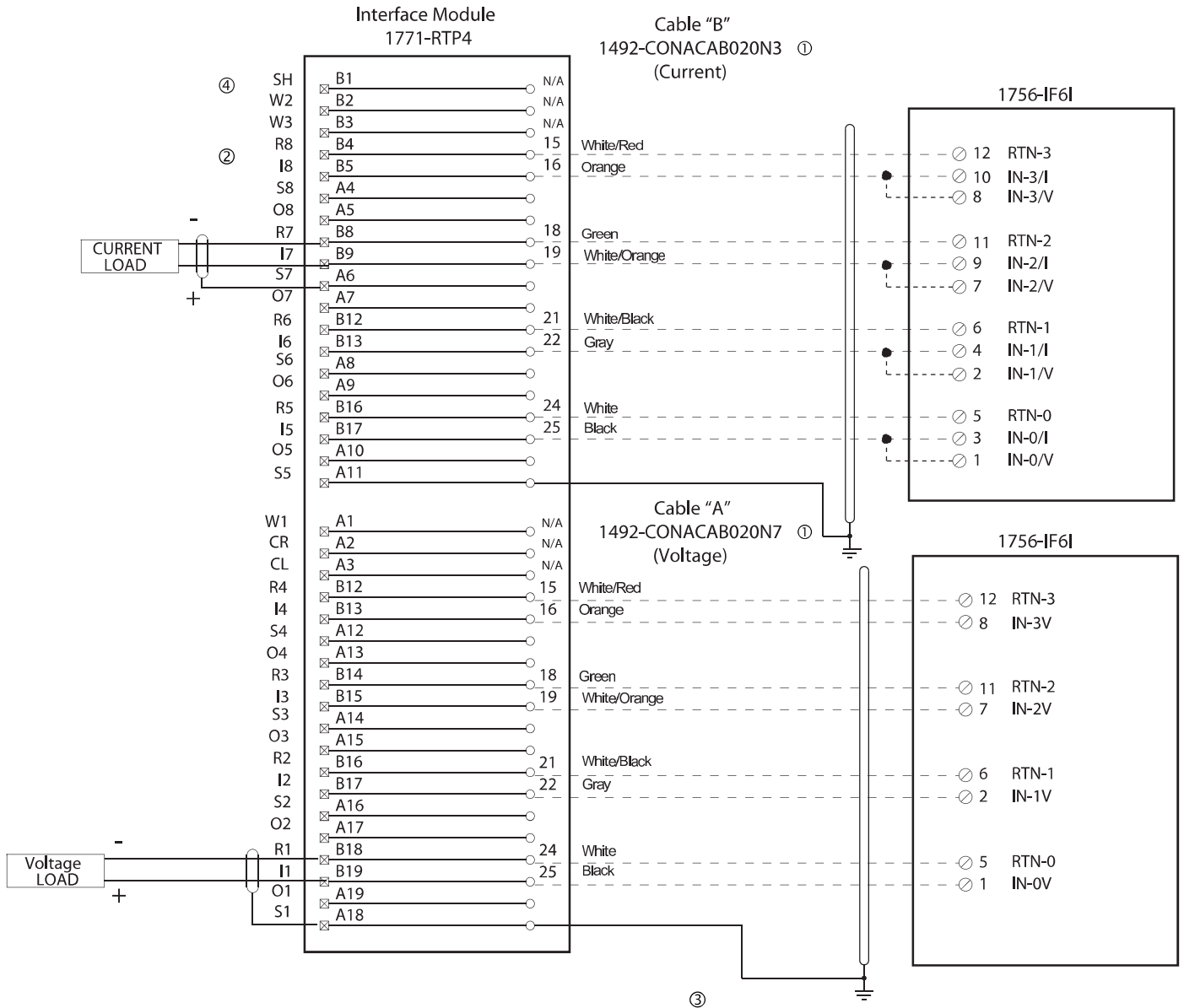

**Interface Module Installation and Application Considerations**

- ① Cables are available in lengths of 2.0M or 5.0M (020=2.0M, 050=5.0M)
- ② Terminals starting with A are the lower row of terminals, B terminals are the upper row.
- ③ Follow your PLC Analog User Manual for proper shield grounding instructions.
- ④ Terminals w1, w2, w3, are spares used for field wire convenience. NOTE: This is only true for module RTP3 and RTP4. The Bul. 1492 cable does not connect to these terminals.

Conversion: 1771-NR (1) To 1756-IRT8I (1) (RTD)  
Using Existing 1771-RTP4 Interface Module



**WARNING**

There are several key application considerations and system specifications (bottom of drawing) when using these components (conversion module, cable and input module). Read and understand these considerations before installation.

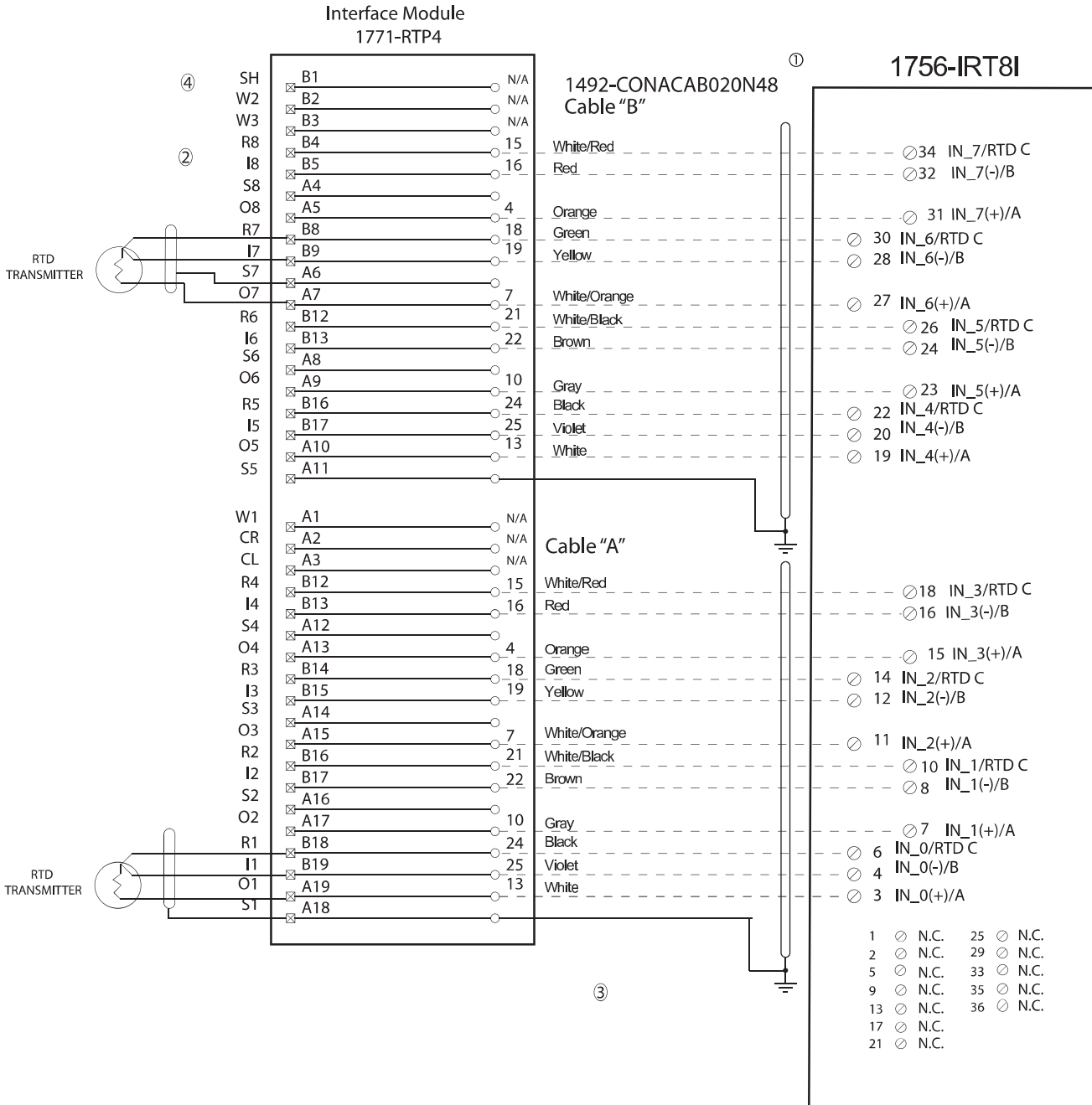

**Interface Module Installation and Application Considerations**

- ① Cables are available in lengths of 2.0M or 5.0M (020=2.0M, 050=5.0M)
- ② Terminals starting with A are the lower row of terminals, B terminals are the upper row.
- ③ Follow your PLC Analog User Manual for proper shield grounding instructions.
- ④ Terminals w1, w2, w3, are spares used for field wire convenience. NOTE: This is only true for module RTP3 and RTP4. The Bul. 1492 cable does not connect to these terminals.

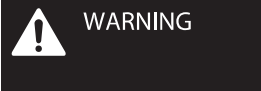

**WARNING**

There are several key application considerations and system specifications (bottom of drawing) when using these components (conversion module, cable and input module). Read and understand these considerations before installation.

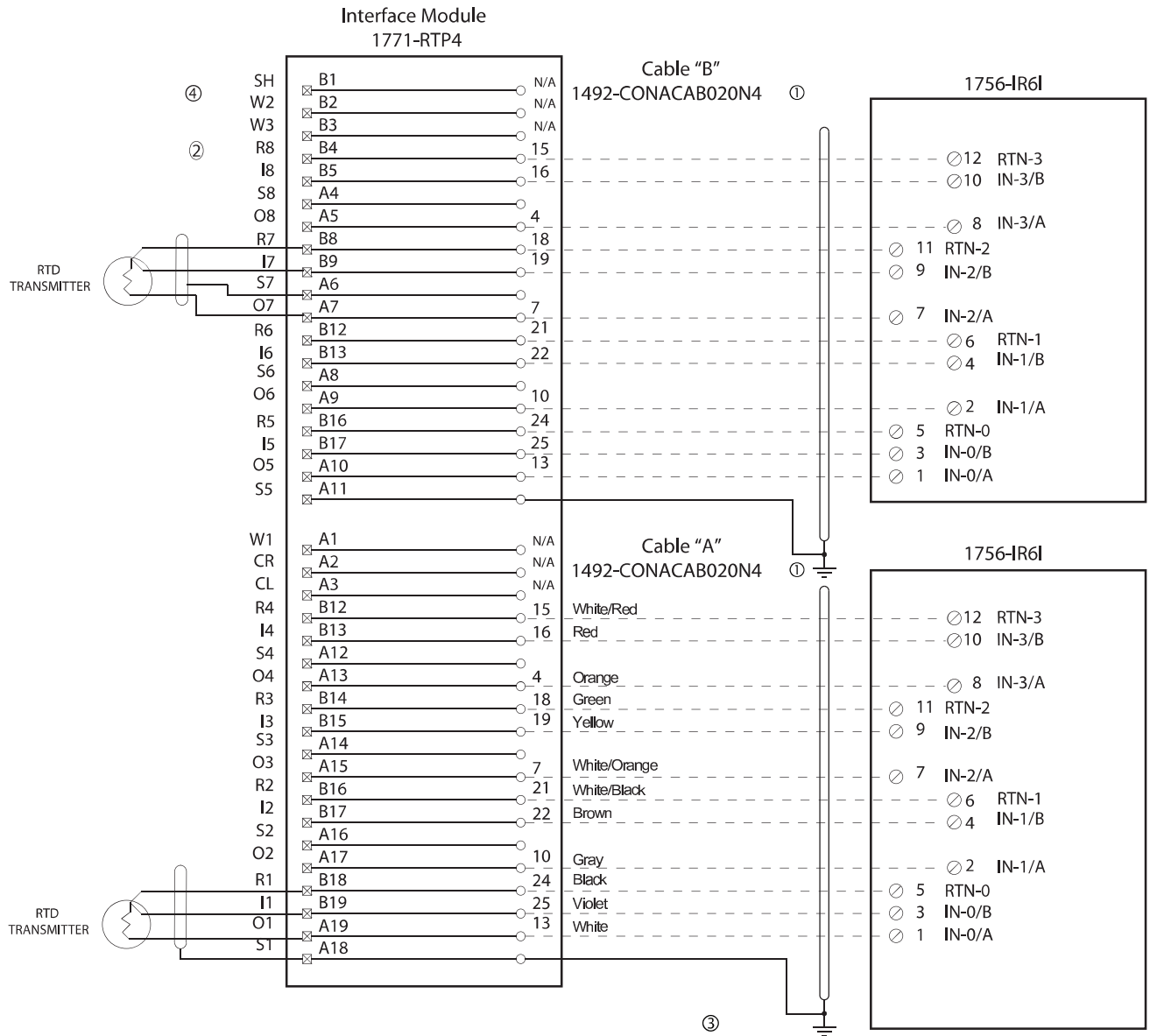

**Interface Module Installation and Application Considerations**

- ① Cables are available in lengths of 2.0M or 5.0M (020=2.0M, 050=5.0M)
- ② Terminals starting with A are the lower row of terminals, B terminals are the upper row.
- ③ Follow your PLC Analog User Manual for proper shield grounding instructions.
- ④ Terminals w1, w2, w3, are spares used for field wire convenience. NOTE: This is only true for module RTP3 and RTP4. The Bul. 1492 cable does not connect to these terminals.



**WARNING** There are several key application considerations and system specifications (bottom of drawing) when using these components (conversion module, cable and input module). Read and understand these considerations before installation.

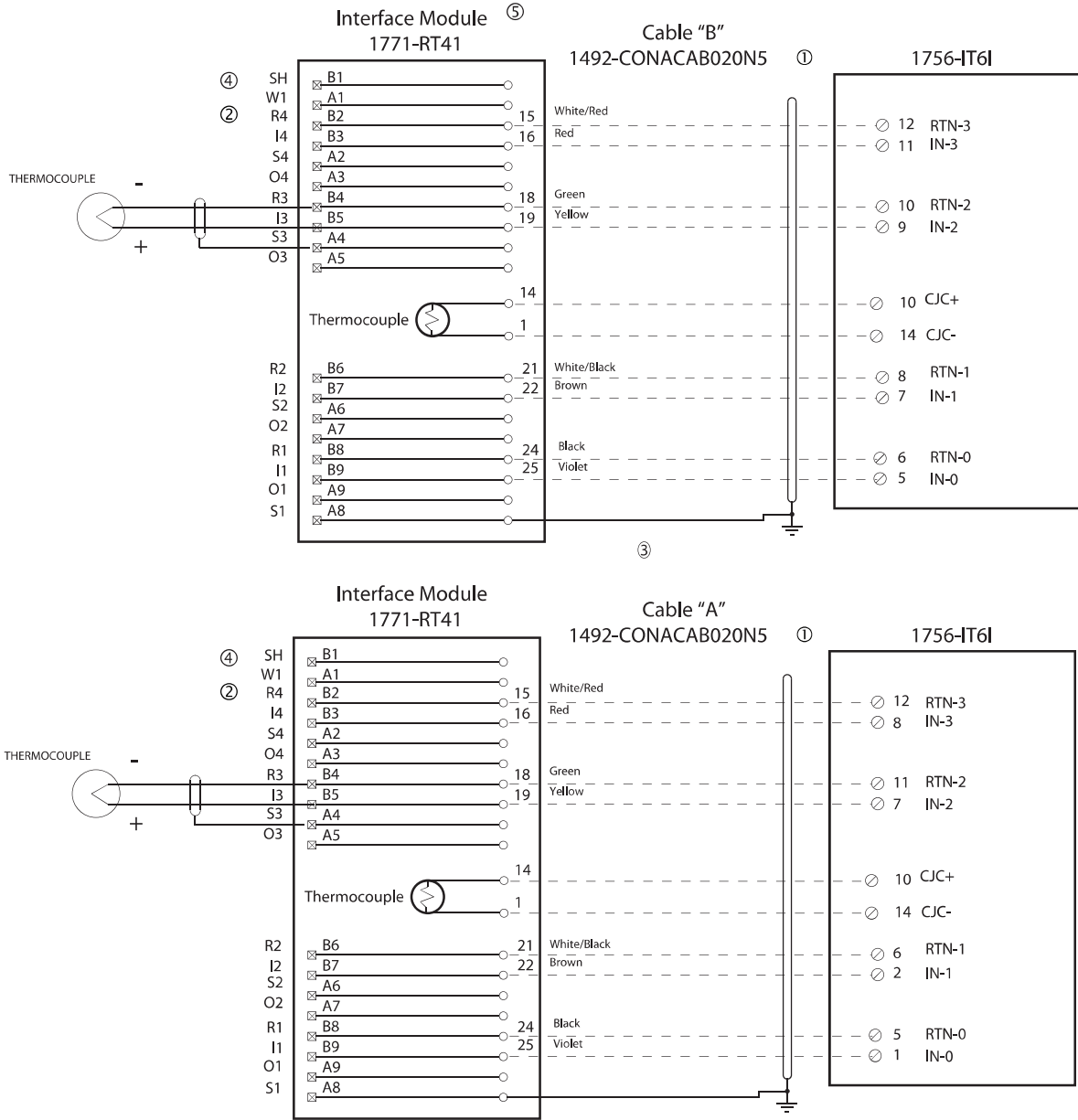

**Interface Module Installation and Application Considerations**

- ① Cables are available in lengths of 2.0M or 5.0M (020=2.0M, 050=5.0M)
- ② Terminals starting with A are the lower row of terminals, B terminals are the upper row.
- ③ Follow your PLC Analog User Manual for proper shield grounding instructions.
- ④ Terminals w1, w2, w3, are spares used for field wire convenience. NOTE: This is only true for module RTP3 and RTP4. The Bul. 1492 cable does not connect to these terminals.
- ⑤ This conversion solution requires replacement of the existing (1) 1771-RTP1 interface module with (2) 1771-RT41 interface modules. Each 1771-RTP1 and RT41 module has there own cold junction compensation thermocouple attached to the interface module.



**WARNING**

There are several key application considerations and system specifications (bottom of drawing) when using these components (conversion module, cable and input module). Read and understand these considerations before installation.

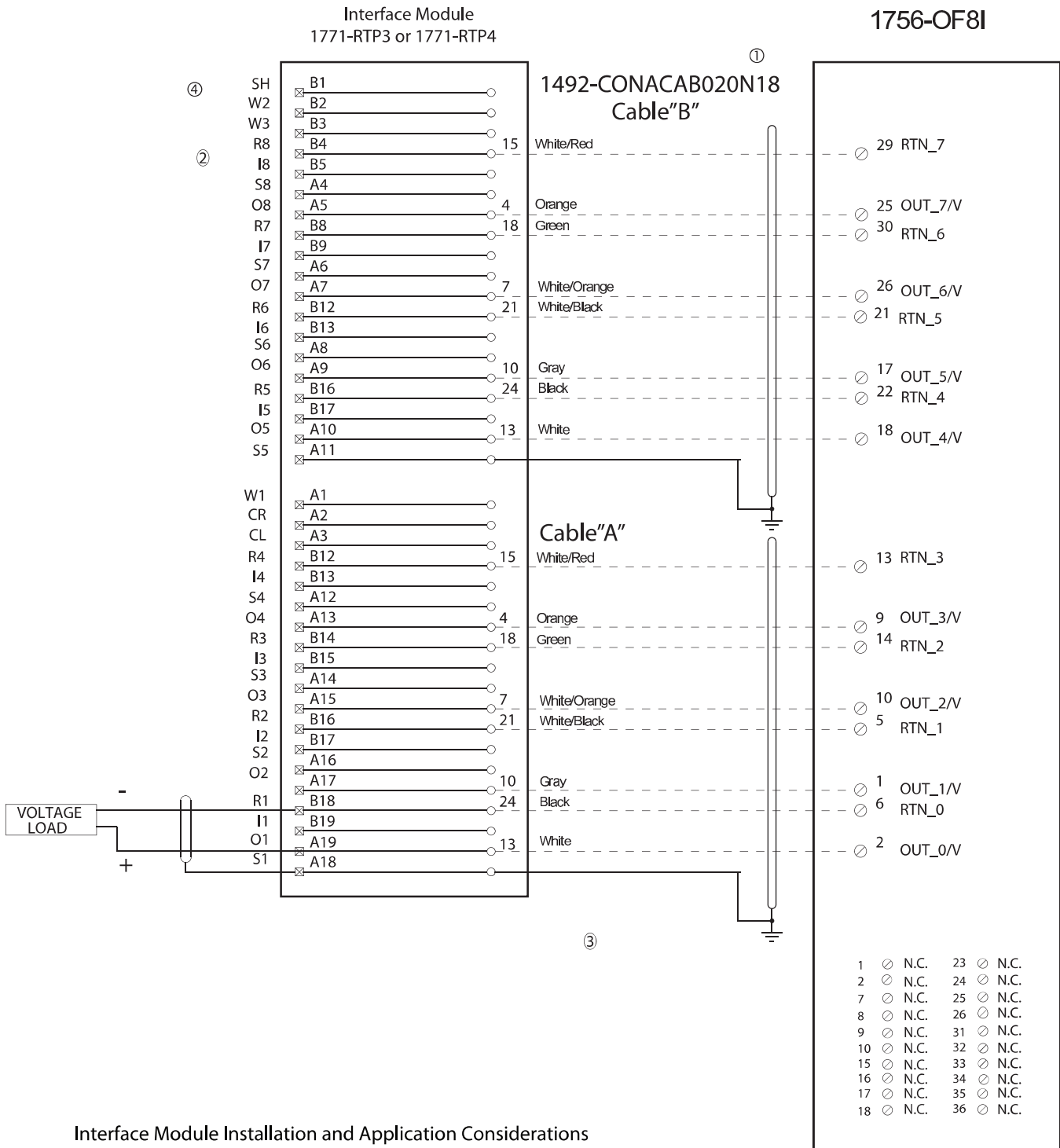

**Interface Module Installation and Application Considerations**

- ① Cables are available in lengths of 2.0M or 5.0M (020=2.0M, 050=5.0M)
- ② Terminals starting with A are the lower row of terminals, B terminals are the upper row.
- ③ Follow your PLC Analog User Manual for proper shield grounding instructions.
- ④ Terminals w1, w2, w3, are spares used for field wire convenience. NOTE: This is only true for module RTP3 and RTP4. The Bul. 1492 cable does not connect to these terminals.



**WARNING**

There are several key application considerations and system specifications (bottom of drawing) when using these components (conversion module, cable and input module). Read and understand these considerations before installation.

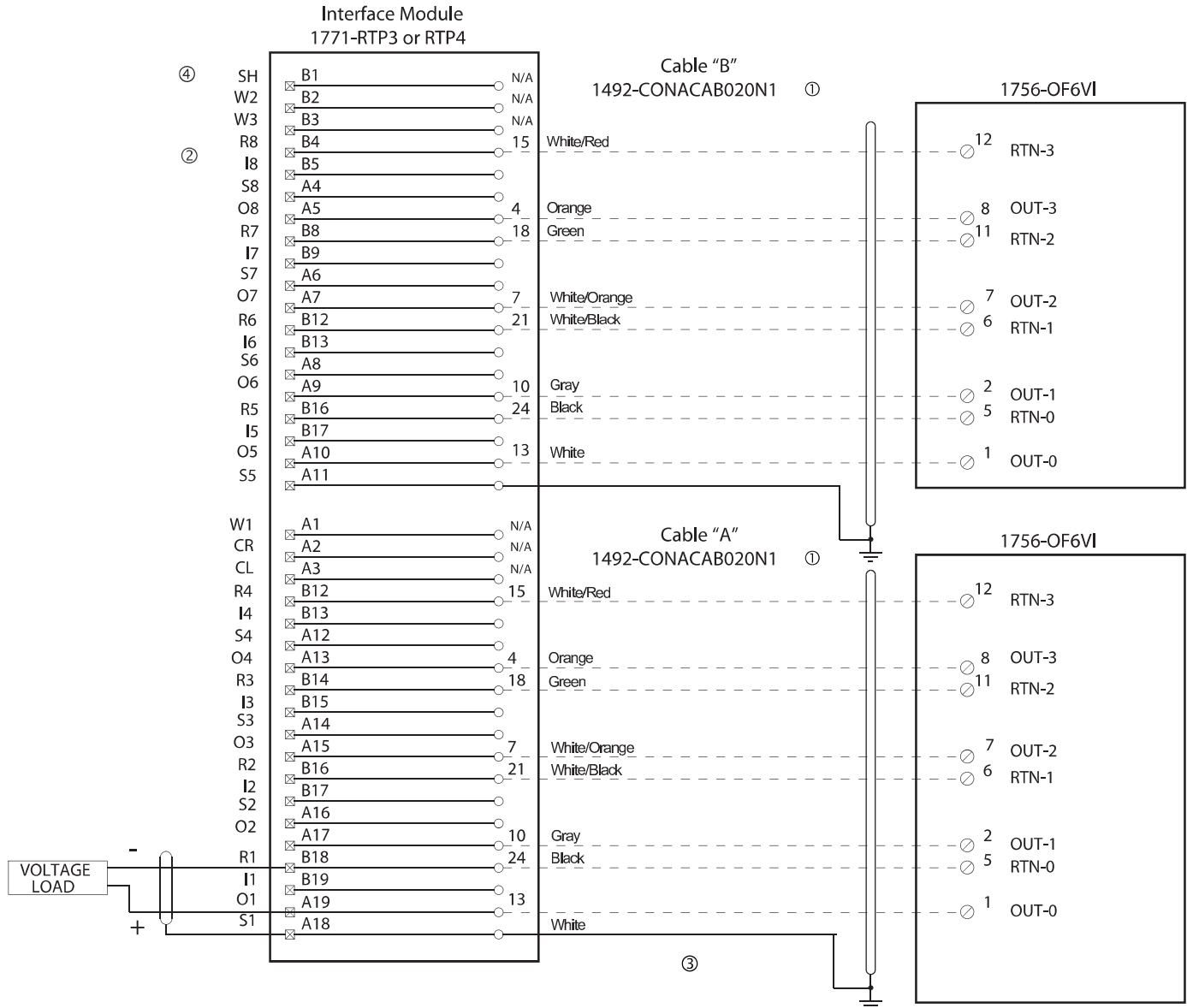

**Interface Module Installation and Application Considerations**

- ① Cables are available in lengths of 2.0M or 5.0M (020=2.0M, 050=5.0M)
- ② Terminals starting with A are the lower row of terminals, B terminals are the upper row.
- ③ Follow your PLC Analog User Manual for proper shield grounding instructions.
- ④ Terminals w1, w2, w3, are spares used for field wire convenience. NOTE: This is only true for module RTP3 and RTP4. The Bul. 1492 cable does not connect to these terminals.





**WARNING**

There are several key application considerations and system specifications (bottom of drawing) when using these components (conversion module, cable and input module). Read and understand these considerations before installation.

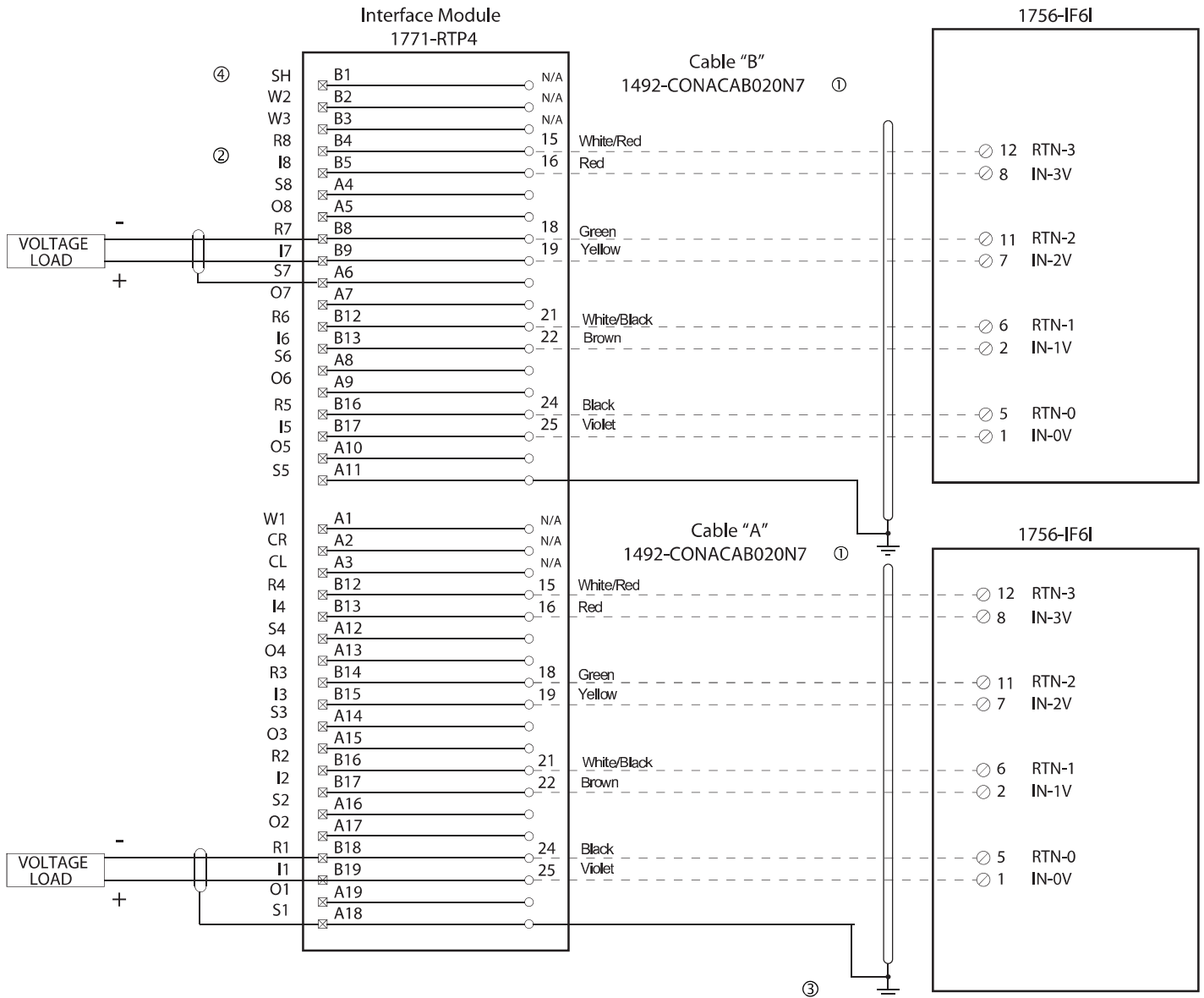

**Interface Module Installation and Application Considerations**

- ① Cables are available in lengths of 2.0M or 5.0M (020=2.0M, 050=5.0M)
- ② Terminals starting with A are the lower row of terminals, B terminals are the upper row.
- ③ Follow your PLC Analog User Manual for proper shield grounding instructions.
- ④ Terminals w1, w2, w3, are spares used for field wire convenience. NOTE: This is only true for module RTP3 and RTP4. The Bul. 1492 cable does not connect to these terminals.



**WARNING**

There are several key application considerations and system specifications (bottom of drawing) when using these components (conversion module, cable and input module). Read and understand these considerations before installation.

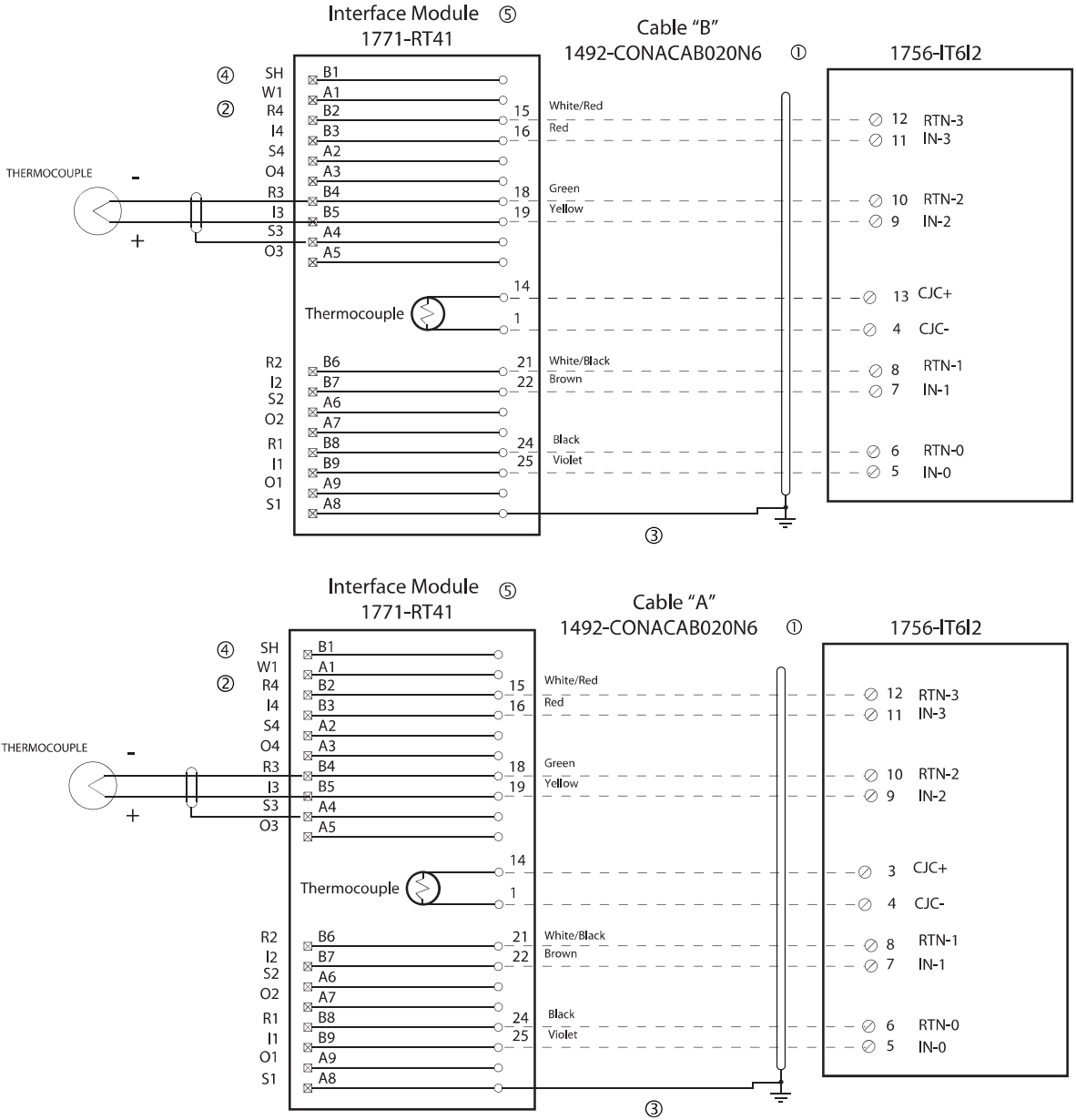

**Interface Module Installation and Application Considerations**

- ① Cables are available in lengths of 2.0M or 5.0M (020=2.0M, 050=5.0M)
- ② Terminals starting with A are the lower row of terminals, B terminals are the upper row.
- ③ Follow your PLC Analog User Manual for proper shield grounding instructions.
- ④ Terminals w1, w2, w3, are spares used for field wire convenience. NOTE: This is only true for module RTP3 and RTP4. The Bul. 1492 cable does not connect to these terminals.
- ⑤ This conversion solution requires replacement of the existing (1) 1771-RTP1 interface module with (2) 1771-RT41 interface modules. Each 1771-RTP1 and RT41 module has there own cold junction compensation thermocouple attached to the interface module.

Conversion: 1771-NIVR (1) To  
 1756-IF8I (1) (Voltage), 1756-IRT8I (1) (RTD)  
 Using Existing 1771-RTP4 Interface Module

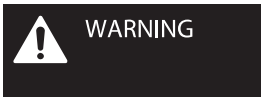

**WARNING**

There are several key application considerations and system specifications (bottom of drawing) when using these components (conversion module, cable and input module). Read and understand these considerations before installation.

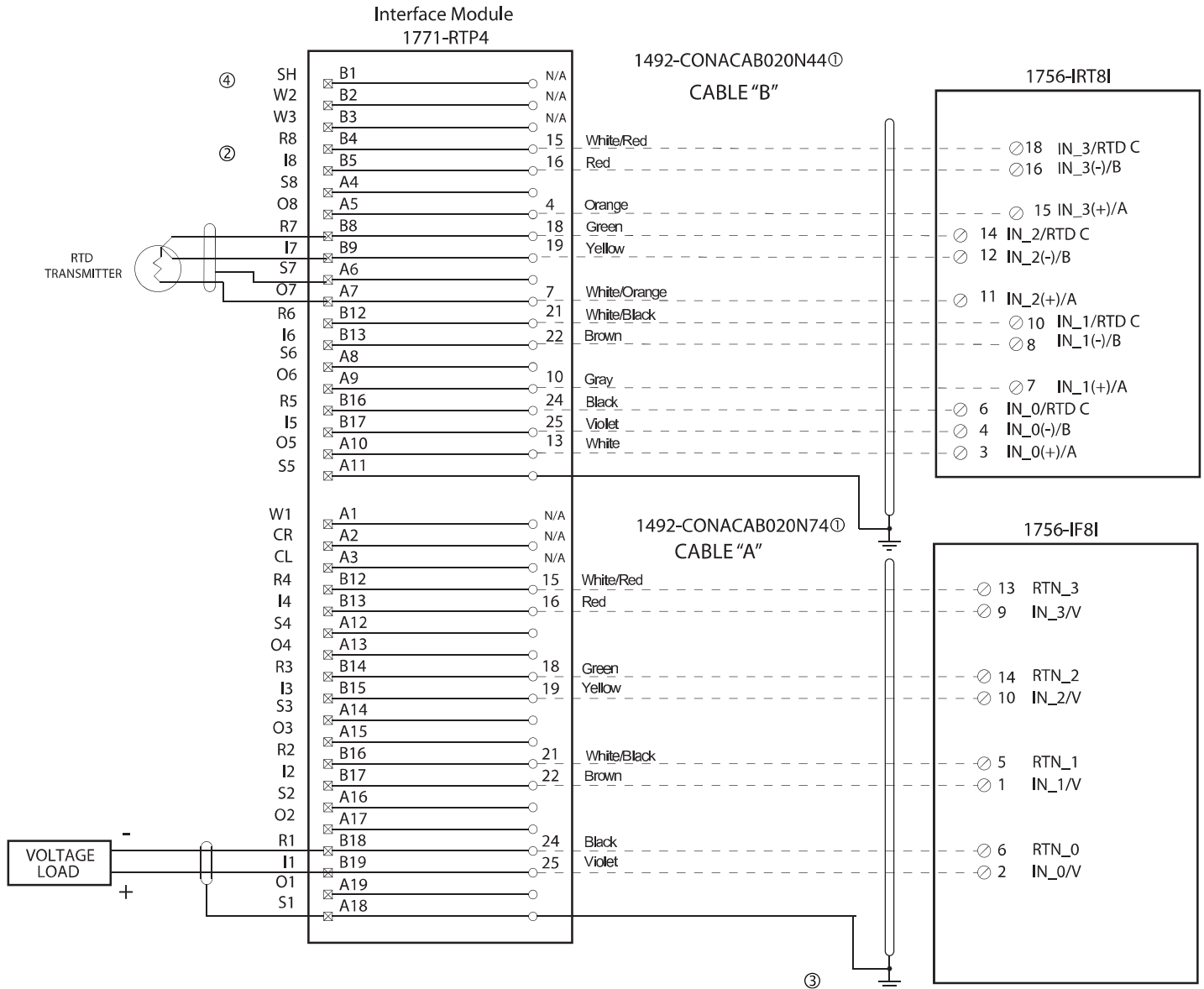

**Interface Module Installation and Application Considerations**

- ① Cables are available in lengths of 2.0M or 5.0M (020=2.0M, 050=5.0M)
- ② Terminals starting with A are the lower row of terminals, B terminals are the upper row.
- ③ Follow your PLC Analog User Manual for proper shield grounding instructions.
- ④ Terminals w1, w2, w3, are spares used for field wire convenience. NOTE: This is only true for module RTP3 and RTP4. The Bul. 1492 cable does not connect to these terminals.

Conversion: 1771-NIVR (1) To  
 1756-IR6I (1) (RTD), 1756-IF6I (1) (Voltage)  
 Using Existing 1771-RTP4 Interface Module



**WARNING**

There are several key application considerations and system specifications (bottom of drawing) when using these components (conversion module, cable and input module). Read and understand these considerations before installation.

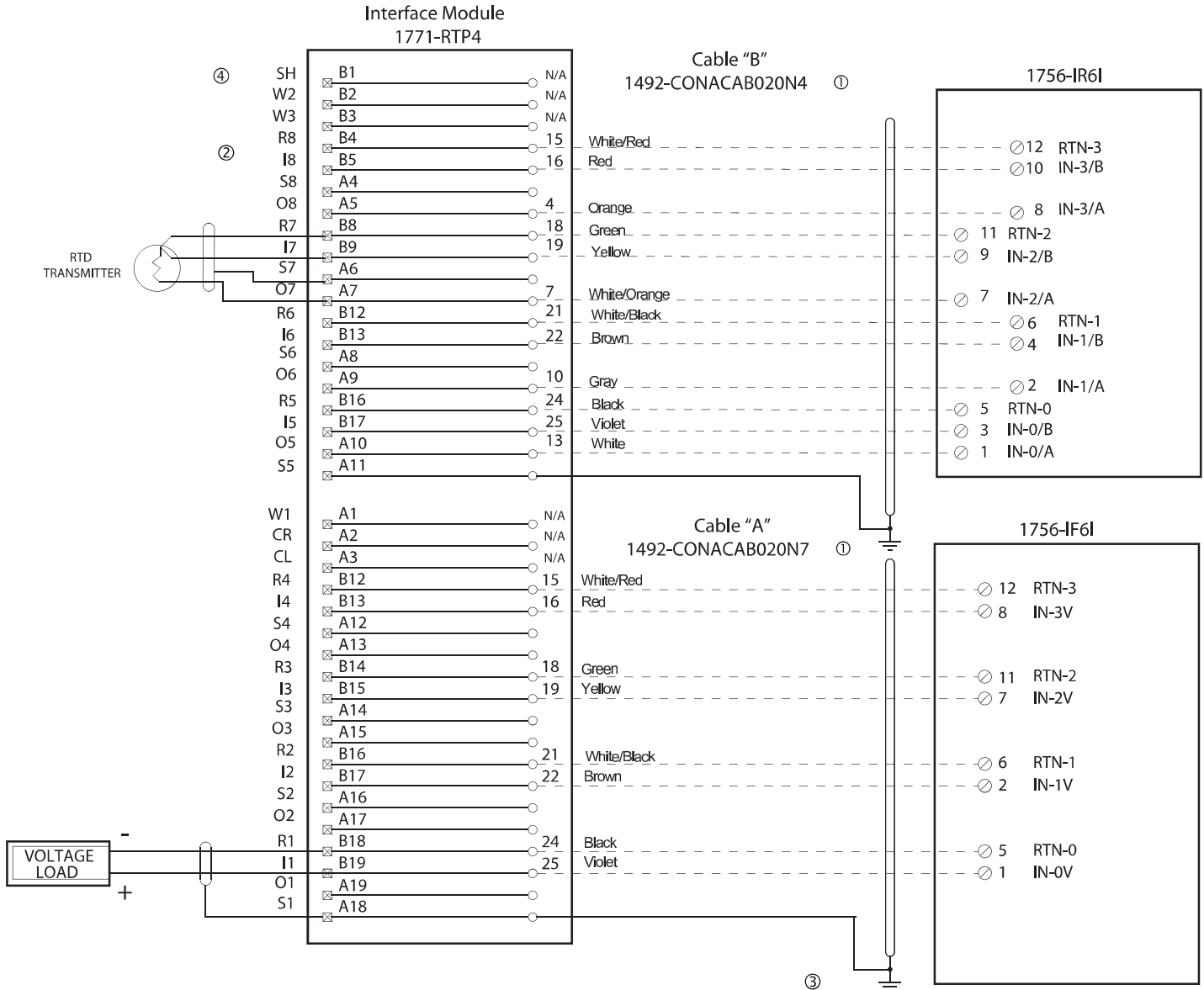

**Interface Module Installation and Application Considerations**

- ① Cables are available in lengths of 2.0M or 5.0M (020=2.0M, 050=5.0M)
- ② Terminals starting with A are the lower row of terminals, B terminals are the upper row.
- ③ Follow your PLC Analog User Manual for proper shield grounding instructions.
- ④ Terminals w1, w2, w3, are spares used for field wire convenience. NOTE: This is only true for module RTP3 and RTP4. The Bul. 1492 cable does not connect to these terminals.

## V. Wiring Diagrams

### Conversion: 1771-NIVR (1) To 1756-IF8I (1) (Current), 1756-IRT8I (1) (RTD) Using Existing 1771-RTP4 Interface Module



#### WARNING

There are several key application considerations and system specifications (bottom of drawing) when using these components (conversion module, cable and input module). Read and understand these considerations before installation.

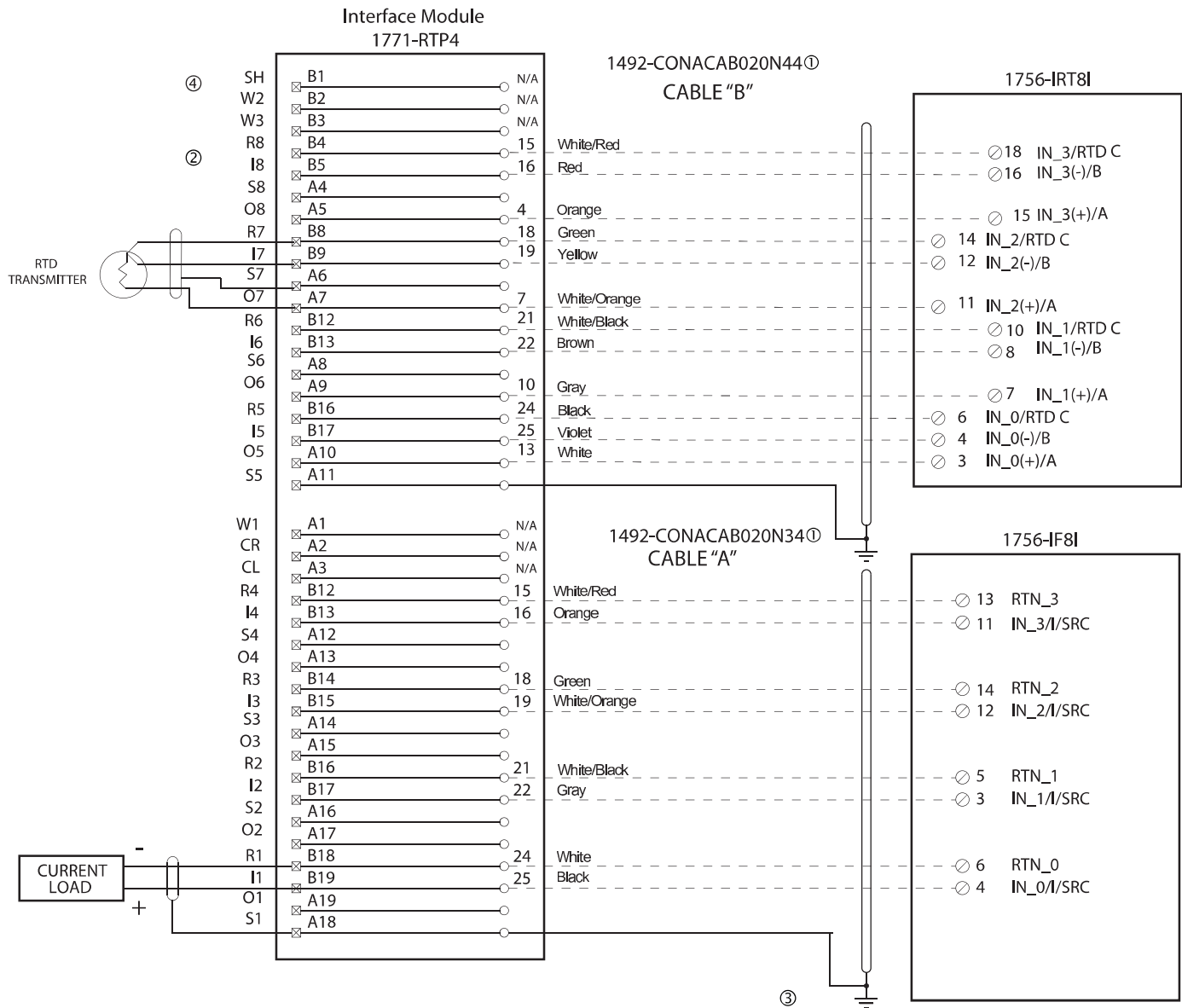

#### Interface Module Installation and Application Considerations

- ① Cables are available in lengths of 2.0M or 5.0M (020=2.0M, 050=5.0M)
- ② Terminals starting with A are the lower row of terminals, B terminals are the upper row.
- ③ Follow your PLC Analog User Manual for proper shield grounding instructions.
- ④ Terminals w1, w2, w3, are spares used for field wire convenience. NOTE: This is only true for module RTP3 and RTP4. The Bul. 1492 cable does not connect to these terminals.

Conversion: 1771-NIVR (1) To  
 1756-IR6I (1) (RTD), 1756-IF6I (1) (Current)  
 Using Existing 1771-RTP4 Interface Module



**WARNING**

There are several key application considerations and system specifications (bottom of drawing) when using these components (conversion module, cable and input module). Read and understand these considerations before installation.

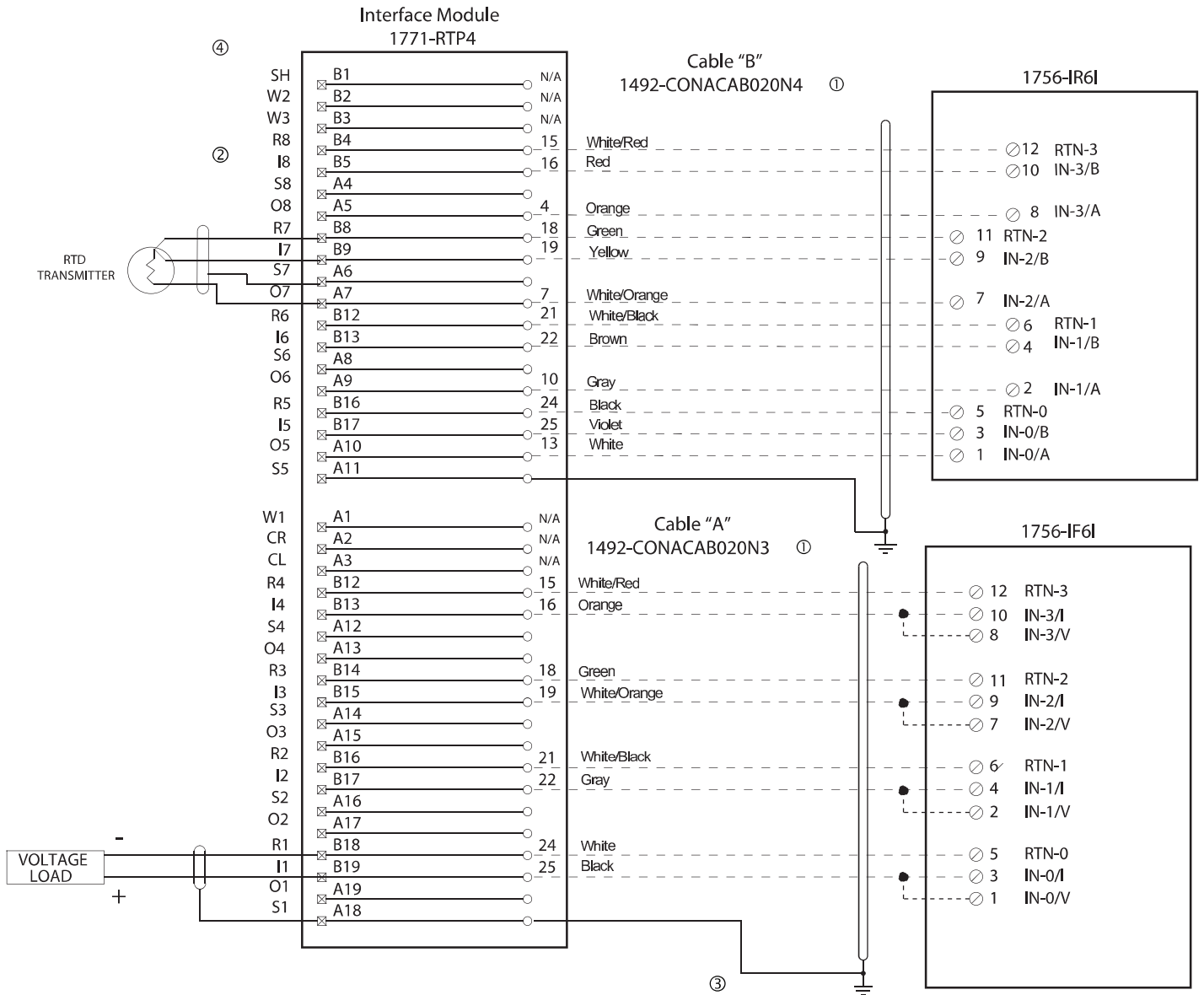

**Interface Module Installation and Application Considerations**

- ① Cables are available in lengths of 2.0M or 5.0M (020=2.0M, 050=5.0M)
- ② Terminals starting with A are the lower row of terminals, B terminals are the upper row.
- ③ Follow your PLC Analog User Manual for proper shield grounding instructions.
- ④ Terminals w1, w2, w3, are spares used for field wire convenience. NOTE: This is only true for module RTP3 and RTP4. The Bul. 1492 cable does not connect to these terminals.