



Safety Manager Release 162



Hardware Reference

EP-SM.MAN.6284

Issue 2.1 | December 2023

- Original Instructions -

General	Type number:	FC-RUSIO-3224
	Operating temperature:	
	<ul style="list-style-type: none"> outside module temperature: 	-40°C ... +70°C (-40°F ... +158°F)
	<ul style="list-style-type: none"> inside module temperature: 	-40°C ... +90°C (-40°F ... +194°F)
	Storage temperature:	-40°C ... +85°C (-40°F ... +185°F)
	Relative humidity:	10 ... 95% (non condensing)
	Pollution:	Pollution degree 2 or better
	Approvals:	CE, UL, TÜV
Power	Supply voltage:	24 V DC -15% ... +30%
	Supply current:	max 300mA (without field load)
IO	Number of channels:	32
	Channel type:	Universal safe (software configurable)
	<ul style="list-style-type: none"> Digital in 	max. 32 (with or without line-monitoring)
	<ul style="list-style-type: none"> ESD in 	max. 1 (with line-monitoring)
	<ul style="list-style-type: none"> Analog in 	max. 32 (with or without line-monitoring)
	<ul style="list-style-type: none"> Digital out 	max. 32 (with or without line-monitoring) max. combined load: 9 A
	<ul style="list-style-type: none"> Analog out 	max. 16 (with or without open loop detection)
	Maximum field capacitance	100 nF (for AI / DI / AO channels) 1 µF (for DO channels)

12 Universal Safety IO

12.1 RUSIO-3224

Physical Data	Dimensions (H x W x D):	145 x 165.1 x 72.4 mm
		5.7 x 6.5 x 2.85 in
	Weight:	0.66 kg
		1.45 lbs

12.2 RUSLS-3224

12.2.1 Universal Safe Logic Solver (32 channels, 24 V DC)

The RUSLS-3224 module has 32 universal safe IO channels with configurable channel function; configuration is done in Safety Builder.

The user can assign execution of application logics to the RUSLS-3224 module for one or more related FLDs; this is called logic solving. Configuration of logic solving is done in Safety Builder.

The RUSLS-3224 module can be used in applications up to SIL 3, in compliance with IEC 61508/61511.

It requires two RUSLS-3224 modules to achieve a redundant configuration.

All channels are powered out of the 24Vdc supply.

Each channel can be configured as:

- Digital input (with or without loop monitoring)
- Digital output (with loop monitoring)
- Analog input (0-20mA or 4-20mA active)
- Analog output (0-20mA or 4-20mA active)

The RUSLS-3224 module supports two (100Mbaud) ethernet links to communicate with a Safety Manager Controller.

The RUSLS-3224 module has a housing that is in line with the patented Series C design of Honeywell. It needs to be placed on an IO Termination Assembly (IOTA).

The below figure shows physical appearance of the RUSLS-3224 module.

12 Universal Safety IO

12.2 RUSLS-3224

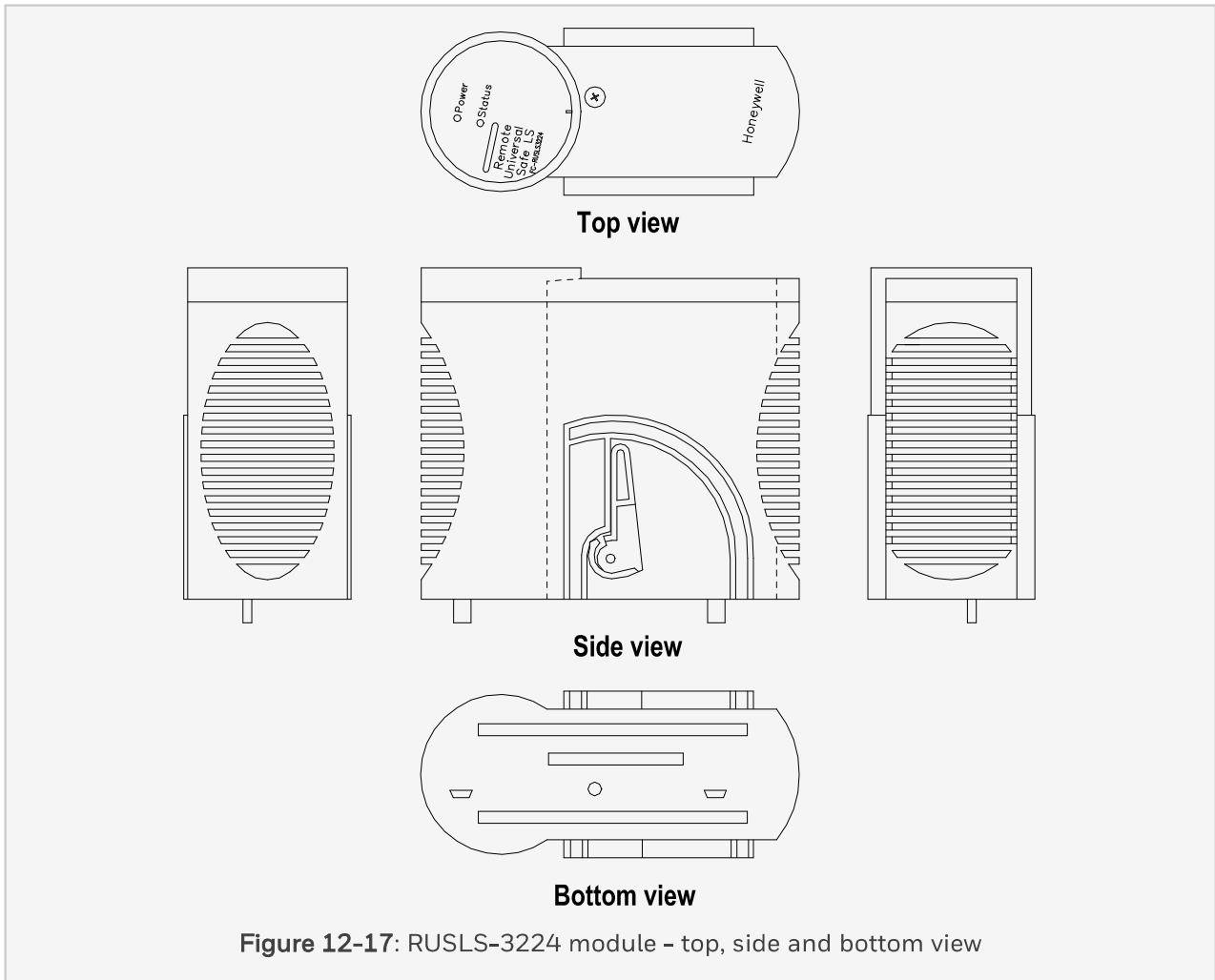

The RUSLS-3224 module has the following features:

- 32 universal IO channels that can be configured to control DI, AI, DO, AO
- Any type of IO field signal has only to be connected to the two connections of the applicable universal channel on the IOTA
- Proven-in-use redundant processor concept that complies with the SIL 3 safety requirements in single channel operation
- Logic solving that enables localized safeguarding of equipment under control (EUC)
- Redundant memory for system and application programs

- A dedicated communication link between these processors
- A redundant communication link with the partner module (in redundant configuration)
- An Ethernet-based Safety Manager Universal I/O link to the Safety Manager Controller in the network via dedicated switches; the Safety Manager Universal I/O link uses a dedicated protocol
- Monitoring the temperature of the electronics
- A configurable ESD function via channel 32 for dedicated safety related functions
- Function-tested watchdogs that: monitor and/or handle:
 - Monitor cycle time and supply voltage
 - Handle the ESD function and memory errors
- LED indicators at the front of the module for power and health status indication
- Real-time clock for Sequence Of Event (SOE) time stamping with a resolution of 1 msec

The RUSLS-3224 module functions as a local Logic Solver and as a Safety Manager universal IO module within the Safety Manager concept. It executes:

- The input scan of the process variables
- All functional tests of its hardware
- Data exchange with its partner module
- The application logics of those FLDs within that are assigned to the module, independently
- Data exchange via the Safety Manager Universal I/O link with the Safety Manager Controller that executes the application logics of those FLDs that are not assigned to the module
- Update the outputs and thus the process

The FLASH nature of the memory allows for on line upgrading within the TÜV-approved concept of both the system software as well as the channel configuration and [parts of] the application program.

12.2.2 Power and status indications

The RUSLS-3224 module has two LEDs; one for power indication and one for status indication (see the below figure).

12 Universal Safety IO

12.2 RUSLS-3224

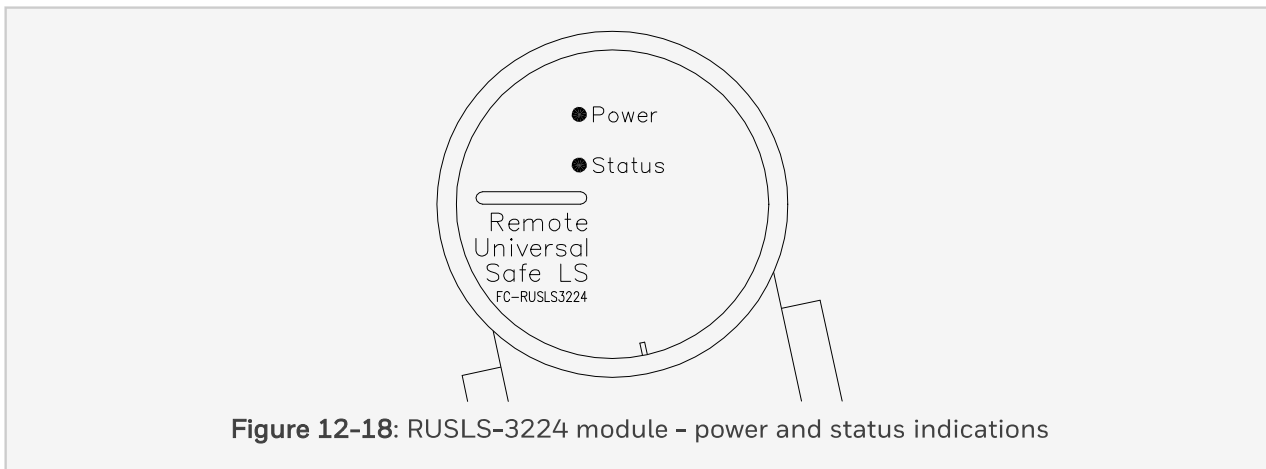

Figure 12-18: RUSLS-3224 module - power and status indications

The table below specifies the applicable indications:

LED indication		Status
Power LED	Green, steady	Power to the module is switched on
	Off	Power to the module is switched off
Status LED	Green, steady	Running without hardware fault
	Red, steady	Running with hardware fault(s)
	Green, flashing, toggle 1 Hz	Idle without hardware fault
	Red, flashing, toggle 1 Hz	Idle with hardware fault(s)
	Red, flashing, toggle 4 Hz	Application / firmware loading
	Off	Module has stopped

12.2.3 Logic solving

The RUSLS-3224 module is capable of logic solving. Logic solving by the module enables localized safeguarding of equipment under control (EUC). This is achieved by the execution of the application logic (FLDs) that is assigned to the module. Configuration of *Remote Universal Safe Logic Solving* is done in Safety Builder; for relevant details see the *Software Reference*.

Localized safeguarding offers distinct benefits. A major advantage is that logic solving by the RUSLS-3224 module is unaffected when:

- communication with Safety Manager is lost,
- Safety Manager experiences a shutdown.

Attention:

A prerequisite for localized safeguarding is that the applicable FLDs only use IOTA resident IO.

Another advantage of localized safeguarding is that it saves execution capacity within the Control Processor of Safety Manager, potentially decreasing its application cycle time.

Execution capacity for localized safeguarding mainly depends on the number of points configured on FLDs that are assigned to the module. Absolute limitations are listed below:

Type	Base	Maximum number
Markers	-	512
Bytes registers	-	256
Counters	-	16
Timers	10 msec	4
	100 msec	32
	1 sec	32
	1 min	16

12.2.4 ESD function

The RUSLS-3224 module has one channel that can be configured as Emergency ShutDown (ESD) input; this is channel 32. To configure channel 32 as ESD input in Safety Builder, the two pins fork on the CN4 terminals on the IOTA must be in the ENABLE position (connecting pins 1 and 2).

Channel 32 must be configured for the ESD function in the software also, in order to execute the proper tests for the ESD channel.

12 Universal Safety IO

12.2 RUSLS-3224

When the (field) switch on the ESD input opens, the Safety Manager universal IO watchdogs switch off and all digital outputs of the connected RUSLS-3224 module(s) will go off and remain off. There is no software action required to do this; also there is no software action that can prevent this.

See detail A of the below figure for a block diagram of this ESD input.

See detail B of the below figure for the ESD input field connection.

The ESD input is line monitored (for short circuit in the field wires).

Place the (1kOhm) line termination resistor on (or near) the switch.

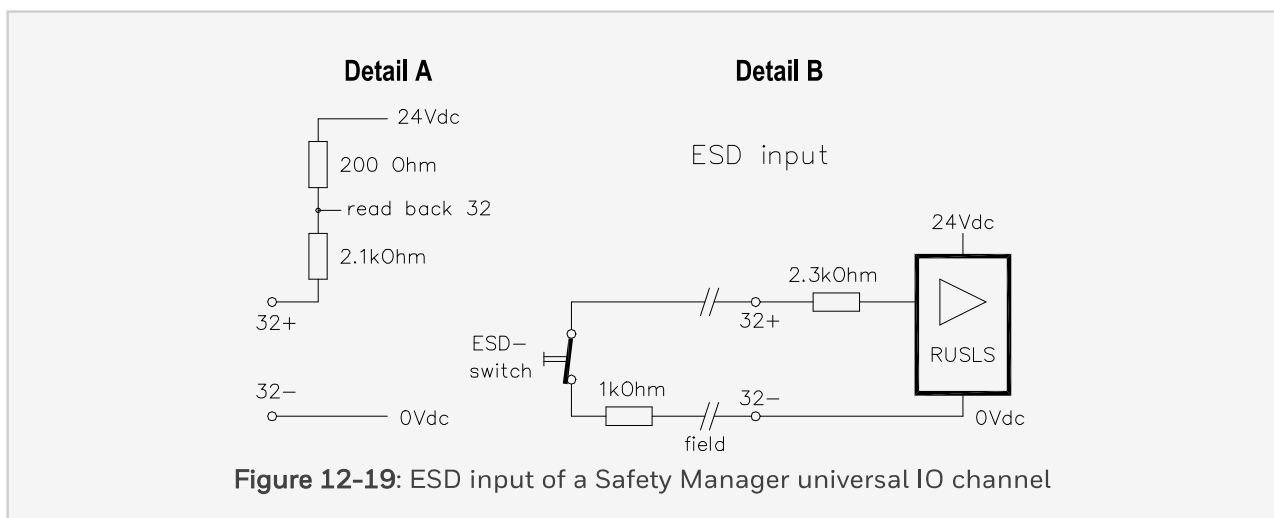

Connecting multiple ESD-inputs of RUSLS-3224 modules with one switch requires a 7.5Volt zener, see the below figure.

All RUSLS-3224 modules involved must be supplied out of the same 24Vdc (power rail).

A 1 Watt zenerdiode - like the 1N4737A or the BZV85-C7V5 - can handle upto 10 ESD inputs of (redundant) RUSLS-3224 modules.

A 5 Watt zenerdiode - like the 1N5343B - can handle upto 50 ESD inputs of (redundant) RUSLS-3224 modules.

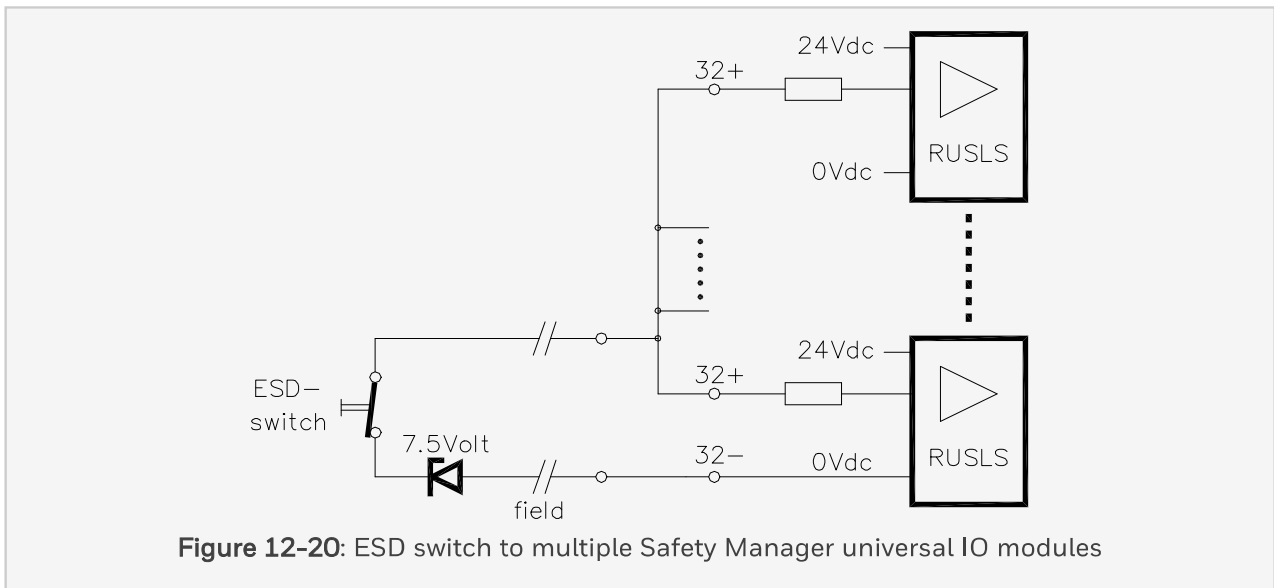

12.2.4.1 Technical Data for an ESD input

Open voltage:	24 V DC -20% ... +30%
Closed contact current:	7 mA ± 5% (at 24Vdc)
Switch resistor (single):	1 kOhm ± 5% >0.25W
Switch zener (multiple):	7.5 Volt
Open contact current:	< 4 mA ± 5%
Short circuit detection:	field resistance < 500 Ohm ± 50%
ESD to outputs off delay:	10 ms ± 30%

12 Universal Safety IO

12.2 RUSLS-3224

12.2.5 IO channels

The RUSLS-3224 module has 32 remote universal safe IO channels.

One RUSLS-3224 module can be placed on a non-redundant IOTA to establish 32 non-redundant channels. Two RUSLS-3224 modules can be placed on one redundant IOTA to establish 32 redundant universal safe IO channels.

Each channel has two screw positions for the connection of field wires on the IOTA. No additional connections for field devices are required.

Positions 1+ through 32+ are the signal connections; one for each of the channels.

Positions 1- through 32- are (all) directly connected with the 0Volt supply connection.

All channels are 24Vdc sourcing ("active").

Each channel can be configured as (line monitored) input or output. Some channels have additional configuration features. In the next topics the features and specific technical data of the various configurations are described. The topic titles reflect the function that a channel will have once it is configured.

12.2.5.1 Line-monitored digital input

The line-monitored input of the RUSLS-3224 module consists of a 250 Ohm resistance and an electronic current limiter. See detail A of the "Line-monitored digital input of a Safety Manager universal IO channel" on the facing page for a block diagram of this Safety Manager universal IO channel configuration.

A line-monitored digital input requires two resistors in the field, near the switching element.

For Normally Closed (field-)contacts, these resistors must be connected in parallel, close to the switch. See detail B of the "Line-monitored digital input of a Safety Manager universal IO channel" on the facing page.

For Normally Open (field-)contacts, these resistors must be connected in series, close to the switch. See detail C of the "Line-monitored digital input of a Safety Manager universal IO channel" on the facing page.

Lead-breakage or short circuit in the wires to the switching element will be detected and result in a warning by the RUSLS-3224.

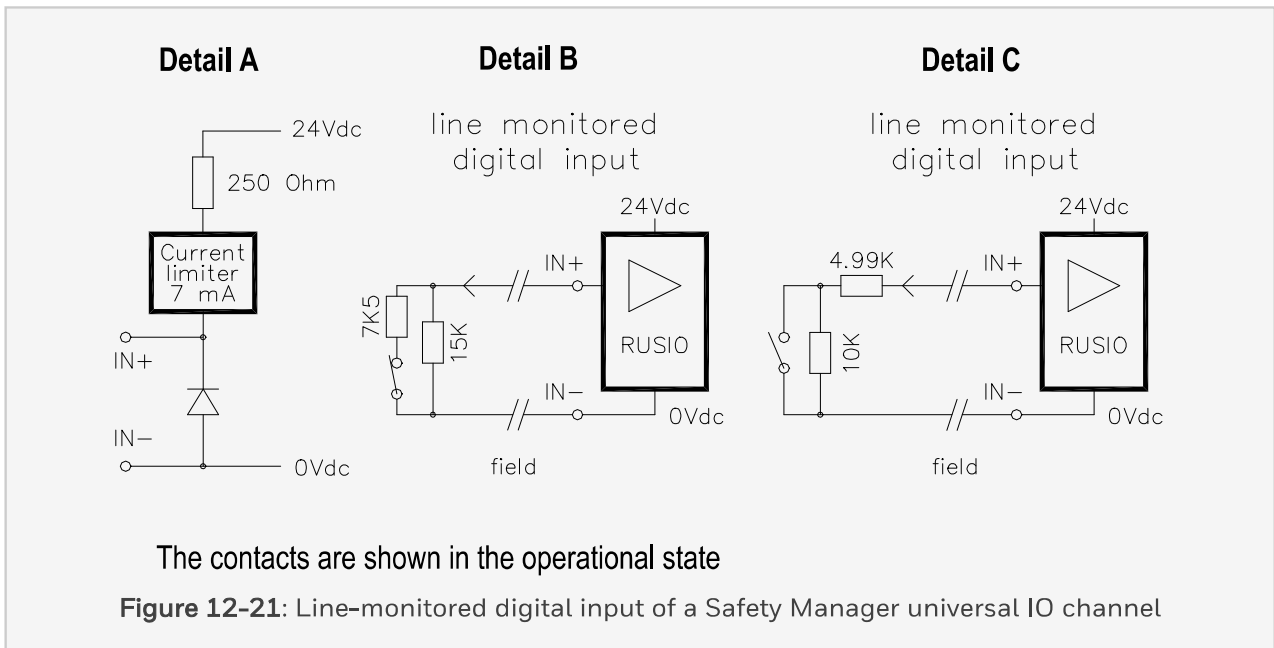

Technical data for a line-monitored digital input

All channels	Open voltage:	24 V DC -20% ... +30%
	Short circuit current:	7 mA ± 5%
	Current limiter voltage drop:	< 1.4 Volt (while NOT limiting)
	Open contact:	15 kOhm ± 5% >0.1 W
	Closed contact:	5 kOhm ± 5% >0.25 W
	Short circuit detection:	I > 6.3 mA ± 5%
	Closed contact detection:	2.8 mA < I < 6.3 mA ± 5%
	Open contact detection:	0.7 mA < I < 2.1 mA ± 5%
	Lead breakage detection:	I < 0.7 mA ± 5%
	Input filter:	first-order low-pass 100 Hz
	Maximum field capacitance:	100 nF

12 Universal Safety IO

12.2 RUSLS-3224

12.2.5.2 Non line-monitored digital input

The non line-monitored input of the RUSIO-3224 module consists of a 250 Ohm resistance and an electronic current limiter. See detail A of the below figure for a block diagram of this Safety Manager universal IO channel configuration.

A non line-monitored digital input has a switching element in the field; see detail B of the below figure.

This input has no short circuit or lead breakage detection.

Attention:

Channels configured as non line-monitored digital inputs may not be used as part of a safety loop.

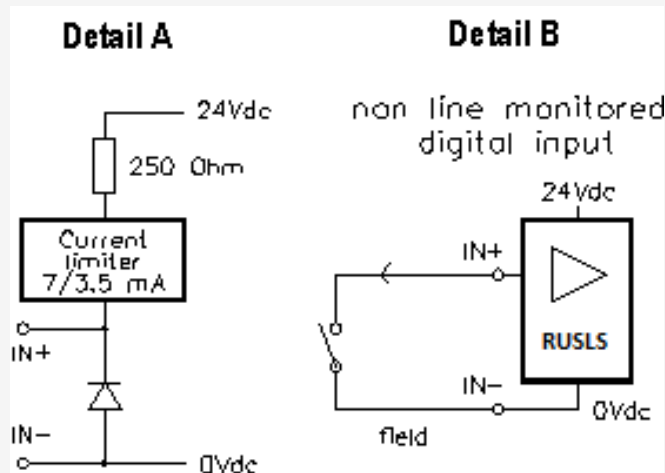

Figure 12-22: Non line-monitored digital input of a Safety Manager universal IO channel

Technical data for a non line-monitored digital input

All channels	Open voltage:	24 V DC -20% ... +30%
	Closed contact current:	7 mA ± 5%, after open state detection
		3.5 mA ± 5%, after closed state detection
	Current limiter voltage drop:	< 1.4 Volt (while NOT limiting)
	Closed contact detection:	I > 2.8 mA ± 5%
	Open contact detection:	I < 2.1 mA ± 5%
	Input filter:	first-order low-pass 100 Hz
	Maximum field capacitance:	100 nF

12.2.5.3 Digital output

The digital output of the RUSLS-3224 module consists of a (0.5 A current limited) output with a Secondary Means Of De-energisation (SMOD) FET output.

Each output has a SMOD to enable switching off the channel, even if the channel FET fails. See detail A of the below figure for an example.

The output driver limits the output (short circuit) current and switches off the output if an overload condition lasts too long.

All digital outputs of a RUSLS-3224 are off when its IO watchdog is tripped.

12 Universal Safety IO

12.2 RUSLS-3224

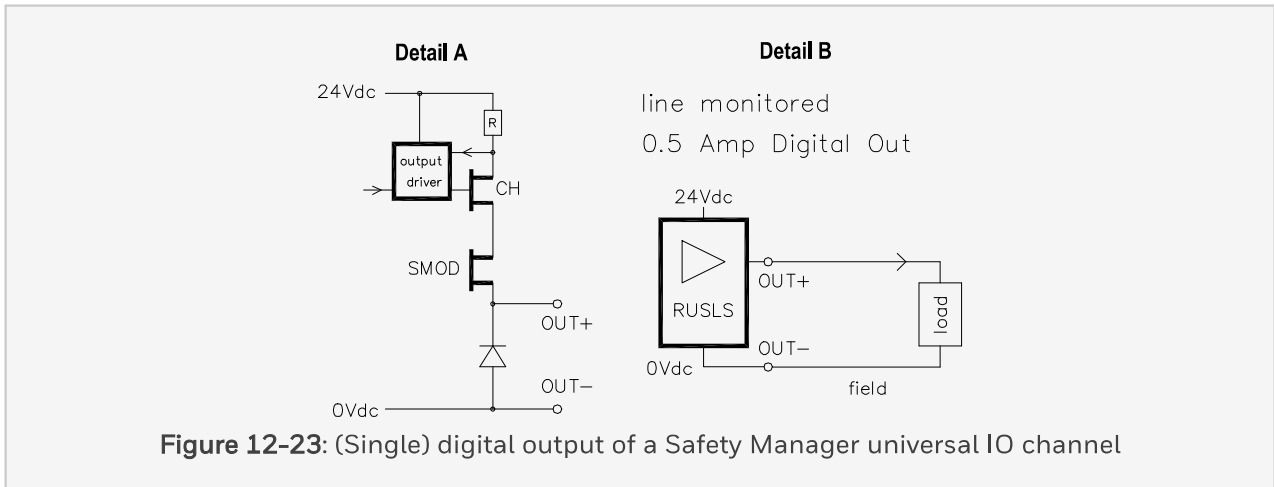

Figure 12-23: (Single) digital output of a Safety Manager universal IO channel

Lead breakage detection in the (field-) wiring is achieved by sourcing a small current (< 0.7 mA) into the field. Failure to conduct this current indicates lead breakage.

Loads of more than 0.5A are supported with the multiple output option.

Sets of two or four outputs can be configured as a multiple output, respectively capable of sourcing up to 1 A or 2 A.

A 2 pins fork with a pitch of 5.08mm (or a 4 pins fork with a pitch of 5.08mm) can be used to interconnect the multiple outputs. See details A and B of the below figure for examples.

The field + wire must be connected with one of the OUT+ pins (together with the fork). Any one of the OUT- pins can be used to connect the field return wire.

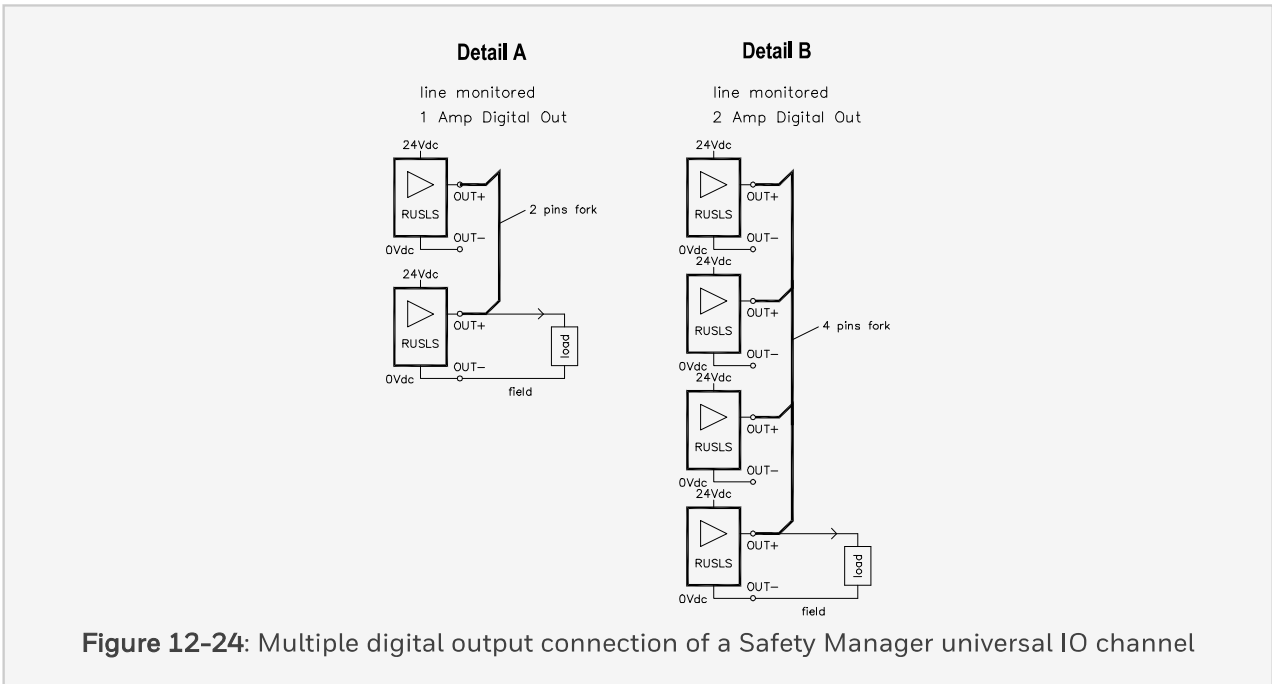

Figure 12-24: Multiple digital output connection of a Safety Manager universal IO channel

12 Universal Safety IO

12.2 RUSLS-3224

Technical data for a digital output

Output:	24 V DC solid-state source
	short circuit proof
Maximum resistive load:	500 mA
	For more details see, <ul style="list-style-type: none"> • Open loop detection for de-energized Universal I/O line-monitored digital output channels • General information about output modules
Maximum tungsten-lamp load:	125mA (3 W)
Minimum load:	1 mA
Maximum field capacitance:	1 μ F For details, see Open loop detection for de-energized Universal I/O line-monitored digital output channels
Maximum inductive load	10 H
Voltage drop:	< 1.5 V (at 500 mA)
Off current:	< 0.1 mA
Two pins fork:	Weidmuller, LPA QB 2
Four pins fork:	Weidmuller, LPA QB 4

12.2.5.4 Analog output 0-20mA and 4-20mA

The analog output of the RUSLS-3224 module consists of a 250 Ohm readback resistor, a current control circuit with output FET (AO) and a SMOD FET. See detail A of the below figure for a block diagram of this Sm universal IO output. Each output has a SMOD to enable switching off the channel, even if the channel FET fails. See details A of the below figure for an example.

An analog output is typically connected with an 0-20mA or 4-20mA analog actuator in the field. See detail B of the below figure for an example.

An analog output can be configured for 0-20mA or 4-20mA and is always active. This means that the RUSLS-3224 module provides the required power.

Short circuit in the wires to the load will not be detected.

If the output is configured for 4-20mA, then lead breakage of the wires will be detected and result in a warning by the RUSLS-3224 module.

Isolated analog output signals require an (Ex-)analog isolator module. See detail C of the below figure for an example of how to connected such an output.

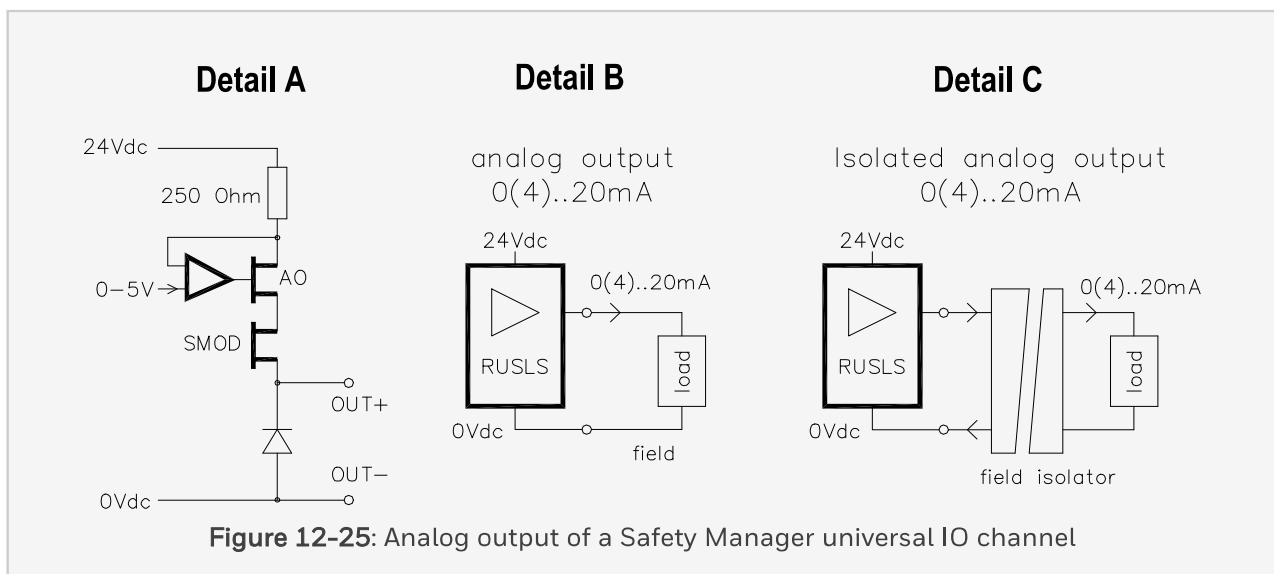

12 Universal Safety IO

12.2 RUSLS-3224

Technical data for an analog output

Open voltage:	24 V DC -20% ... +30%
Output current:	0 - 23 mA
Field (loop) resistance:	max. 500 Ohm
D-A conversion:	12 bit
Inaccuracy:	< 0.5% of full scale
Safety-related inaccuracy	< 1% of full scale

12.2.6 Temperature derating

This sub section addresses 'outside module temperature'. The maximum outside module temperature must be limited depending on the internal dissipation.

Attention:

1. Airflow in / through the module is assumed to be natural convection.
2. Make sure that RUSLS-3224 modules are installed in the correct position. A RUSLS-3224 module must be mounted in upright position (refer to the "RUSLS-3224 module installation position" on the facing page).

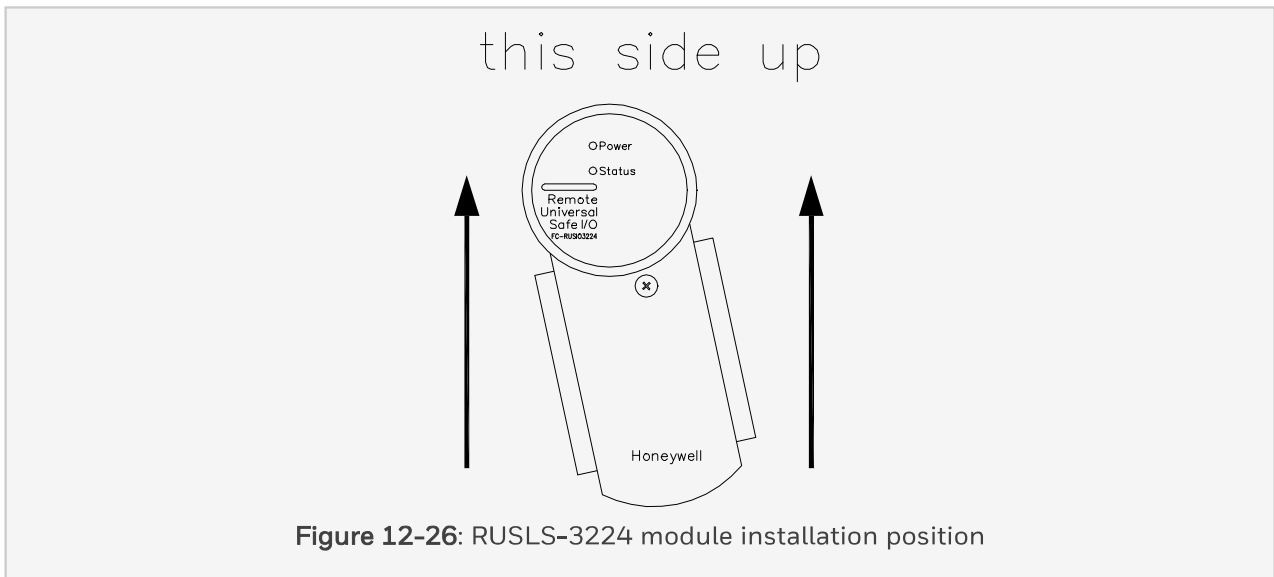

To determine the maximum acceptable outside module temperature for a typical configuration do the steps below. Relevant details are given in separate topics.

12 Universal Safety IO

12.2 RUSLS-3224

Outline of the procedure	For details see
<p>Perform the Internal dissipation calculation.</p> <ol style="list-style-type: none"> 1. Determine which supply voltage applies to your configuration: <ul style="list-style-type: none"> • 25 V or less, • more than 25 V or unknown. 2. Select the applicable reference table 3. Determine and record the actual configuration data. 4. Calculate the totals per dissipation contributor. 5. Add the totals of the previous step to determine the internal dissipation. 	<p>Internal dissipation calculation</p>
<p>Determine the maximum acceptable outside module temperature. Use the applicable derating curve, based on the supply voltage:</p> <ul style="list-style-type: none"> • 25 V or less: use the derating curve in "Module derating with a supply voltage of 25 V default" on page 615. • More than 25 V or unknown: use the derating curve in "Module derating with a supply voltage of 31.2 V" on page 617. 	<p>"Module derating with a supply voltage of 25 V default" on page 615</p> <p>"Module derating with a supply voltage of 31.2 V" on page 617</p>

Tip:

You can make a print of the applicable calculation table to make annotations of your specific configuration(s). Make sure to fill in the table for the applicable supply voltage.

12.2.6.1 Internal dissipation calculation

To calculate the maximum outside module temperature, you need the configuration. The maximum dissipation caused by the logic of the RUSLS-3224 module is a fixed value. Other dissipation

contributions depend on the channel configuration. The maximum dissipation per channel type depends on the applicable supply voltage.

Select the appropriate table to carry out the calculation, based on the supply voltage:

- 25 V or less: 25 V (default) - shown in the below table,
- More than 25 V or unknown: 31.2 V (maximum) - shown in the below table.

Table 1. Dissipation calculation - supply voltage 25 V

Dissipation contributor (P)	Max. dissipation per channel [W]	Number of configured channels	Dissipation [W]
Logic			5.5
DI-LM; field impedance ≥ 5 KOhm	0.01		
DI; closed contact; 3.5 mA	0.085		
AI; < 24 mA; Current limited by field	0.05		
AI; > 24 mA; Current limited by RUSLS ¹	0.49		
DO; <0.3 A	0.115		
DO; <0.5 A	0.305		
AO; 500 Ohm field impedance; < 23 mA	0.225		
AO; 250 Ohm field impedance; < 23 mA	0.335		
AO; < 250 Ohm; < 23 mA	0.47		
AO; < 250 Ohm; < 20 mA	0.42		
Total Power Dissipation (TPD) [W]			
Max. outside module temperature [°C]			
<p>1. Analogue input currents above 24 mA should be avoided. Field devices for the analogue input should be configured to drive currents below 24 mA, e.g. 3.5 mA for sensor fault conditions to minimize the Safety Manager universal IO internal power dissipation. The thin-line derating curve needs to be taken when using currents above 24 mA.</p>			

Good practice for the high dissipating channels is:

1. To distribute them over the two IO boards in the module between CH1-16 and CH17-32.
2. To select the channels at the bottom of the IO boards (near CH16 and CH32).

Table 2. Dissipation calculation - supply voltage 31.2 V

Dissipation contributor (P)	Max. dissipation per channel [W]	Number of configured channels	Dissipation [W]
Logic			5.5
DI-LM; field impedance ≥ 5 KOhm	0.01		
DI; closed contact; 3.5 mA	0.085		
AI; < 24 mA; Current limited by field	0.05		
AI; > 24 mA; Current limited by RUSLS ¹	0.64		
DO; < 0.3 A	0.115		
DO; < 0.5 A	0.305		
AO; 500 Ohm field impedance; < 23 mA	0.345		
AO; 250 Ohm field impedance; < 23 mA	0.48		
AO; < 250 Ohm; < 23 mA	0.61		
AO; < 250 Ohm; < 20 mA	0.545		
Total Power Dissipation (TPD) [W]			
Max. outside module temperature [°C]			
<p>1. Analogue input currents above 24 mA should be avoided. Field devices for the analogue input should be configured to drive currents below 24 mA, e.g. 3.5 mA for sensor fault conditions to minimize the Safety Manager universal IO internal power dissipation. The thin-line derating curve needs to be taken when using currents above 24 mA.</p>			

Good practice for the high dissipating channels is:

1. To distribute them over the two IO boards in the module between CH1-16 and CH17-32.
2. To select the channels at the bottom of the IO boards (near CH16 and CH32).

12 Universal Safety IO

12.2 RUSLS-3224

12.2.6.2 Temperature derating curves (25 V supply voltage)

The below figure shows the maximum outside module temperature versus the internal power dissipation. It shows the derating curves for 25 V supply voltage.

An example calculation for this supply voltage is given in the below table.

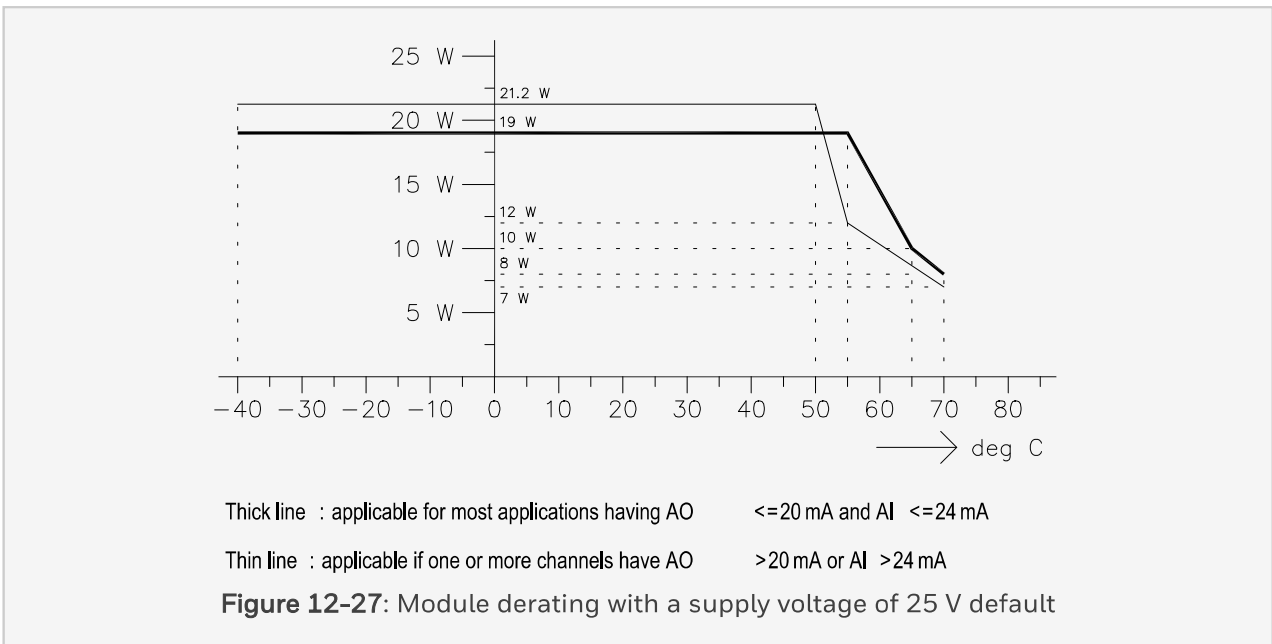

The below table shows a calculation example using the table for a 25 V supply voltage. The column “Number of configured channels” is filled in for the actual situation. Totals per channel type are calculated in the column “Dissipation contribution”.

The “Total internal power dissipation” is calculated at the bottom. Using the applicable line in the "Module derating with a supply voltage of 25 V default" above the maximum outside module temperature is deduced.

In this example the maximum outside module temperature allowed is 70°C, with the High temperature shutdown of the module set at 90°C.

Note:
 The maximum outside temperature limit can be improved with forced airflow.

Table 3. Example: dissipation calculation - supply voltage 25 V

Dissipation contributor (P)	Max. dissipation per channel [W]	Number of configured channels	Dissipation [W]
Logic			5.5
DI-LM; field impedance ≥ 5 KOhm	0.01	10	0.1
DI; closed contact; 3.5 mA	0.085		
AI; < 24 mA; Current limited by field	0.05	10	0.5
AI; > 24 mA; Current limited by RUSLS ¹	0.49		
DO; < 0.3 A	0.115	10	1.15
DO; < 0.5 A	0.305		
AO; 500 Ohm field impedance; < 23 mA	0.225		
AO; 250 Ohm field impedance; < 23 mA	0.335	2	0.67
AO; < 250 Ohm; < 23 mA	0.47		
AO; < 250 Ohm; < 20 mA	0.42		
Total Power Dissipation (TPD) [W]			7.92
Max. outside module temperature [°C]			70
<p>1. Analogue input currents above 24 mA should be avoided. Field devices for the analogue input should be configured to drive currents below 24 mA, e.g. 3.5 mA for sensor fault conditions to minimize the Safety Manager universal IO internal power dissipation. The thin-line derating curve needs to be taken when using currents above 24 mA.</p>			

12.2.6.3 Temperature derating curves (31.2 V supply voltage)

The below figure shows the maximum outside module temperature versus the internal power dissipation. It shows the derating curves for 31.2 V supply voltage.

12 Universal Safety IO

12.2 RUSLS-3224

An example calculation for this supply voltage is given in the below table.

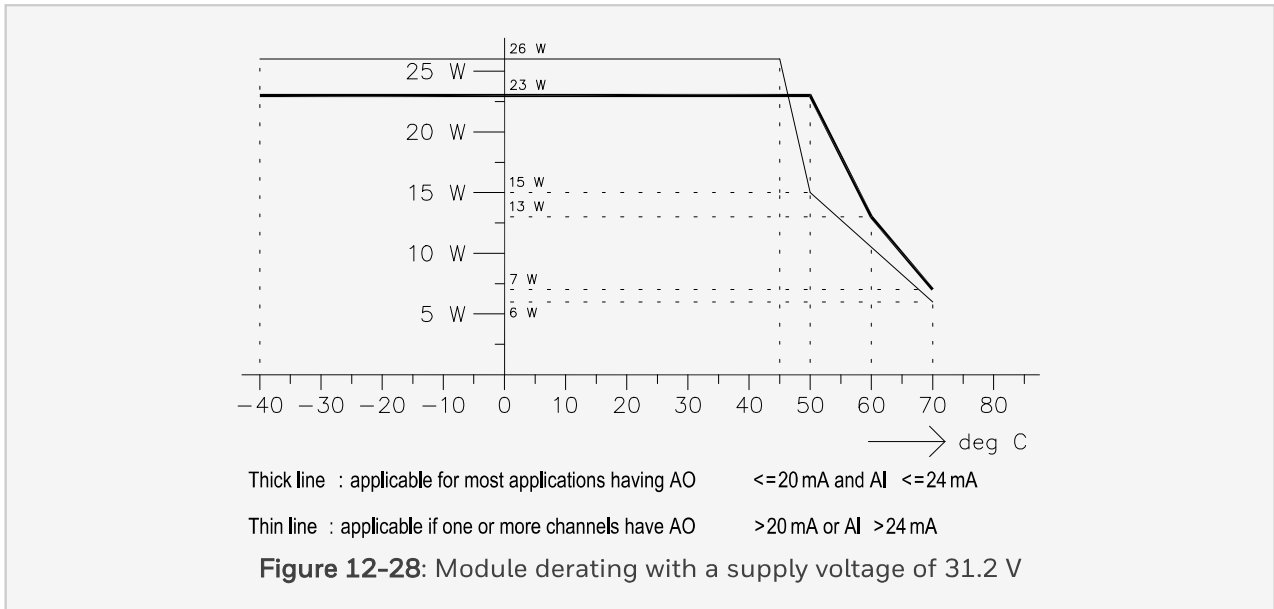

The below table shows a calculation example using the table for a 31.2 V supply voltage. The column “Number of configured channels” is filled in for the actual situation. Totals per channel type are calculated in the column “Dissipation contribution”.

The “Total internal power dissipation” is calculated at the bottom. Using the applicable line in the above figure the maximum outside module temperature is deduced.

In this example the maximum outside module temperature allowed is 65°C, with the High temperature shutdown of the module set at 90°C.

Note:

The maximum outside temperature limit can be improved with forced airflow.

Table 4. Example: dissipation calculation - supply voltage 31.2 V

Dissipation contributor (P)	Max. dissipation per channel [W]	Number of configured channels	Dissipation [W]
Logic			5.5
DI-LM; field impedance ≥ 5 KOhm	0.01	2	0.02
DI; closed contact; 3.5 mA	0.085		
AI; < 24 mA; Current limited by field	0.05	21	1.05
AI; > 24 mA; Current limited by RUSLS ¹	0.64		
DO; < 0.3 A	0.115		
DO; < 0.5 A	0.305	9	2.75
AO; 500 Ohm field impedance; < 23 mA	0.345		
AO; 250 Ohm field impedance; < 23 mA	0.48		
AO; < 250 Ohm; < 23 mA	0.61		
AO; < 250 Ohm; < 20 mA	0.545		
Total Power Dissipation (TPD) [W]			9.32
Max. outside module temperature [°C]			65
<p>1. Analogue input currents above 24 mA should be avoided. Field devices for the analogue input should be configured to drive currents below 24 mA, e.g. 3.5 mA for sensor fault conditions to minimize the Safety Manager universal IO internal power dissipation. The thin-line derating curve needs to be taken when using currents above 24 mA.</p>			

12 Universal Safety IO

12.2 RUSLS-3224

12.2.7 Power supply ripple (24 V DC supply voltage)

The Safety Manager with Universal IO can tolerate a distortion or ripple on the 24 V DC power supply as defined in the following graph.

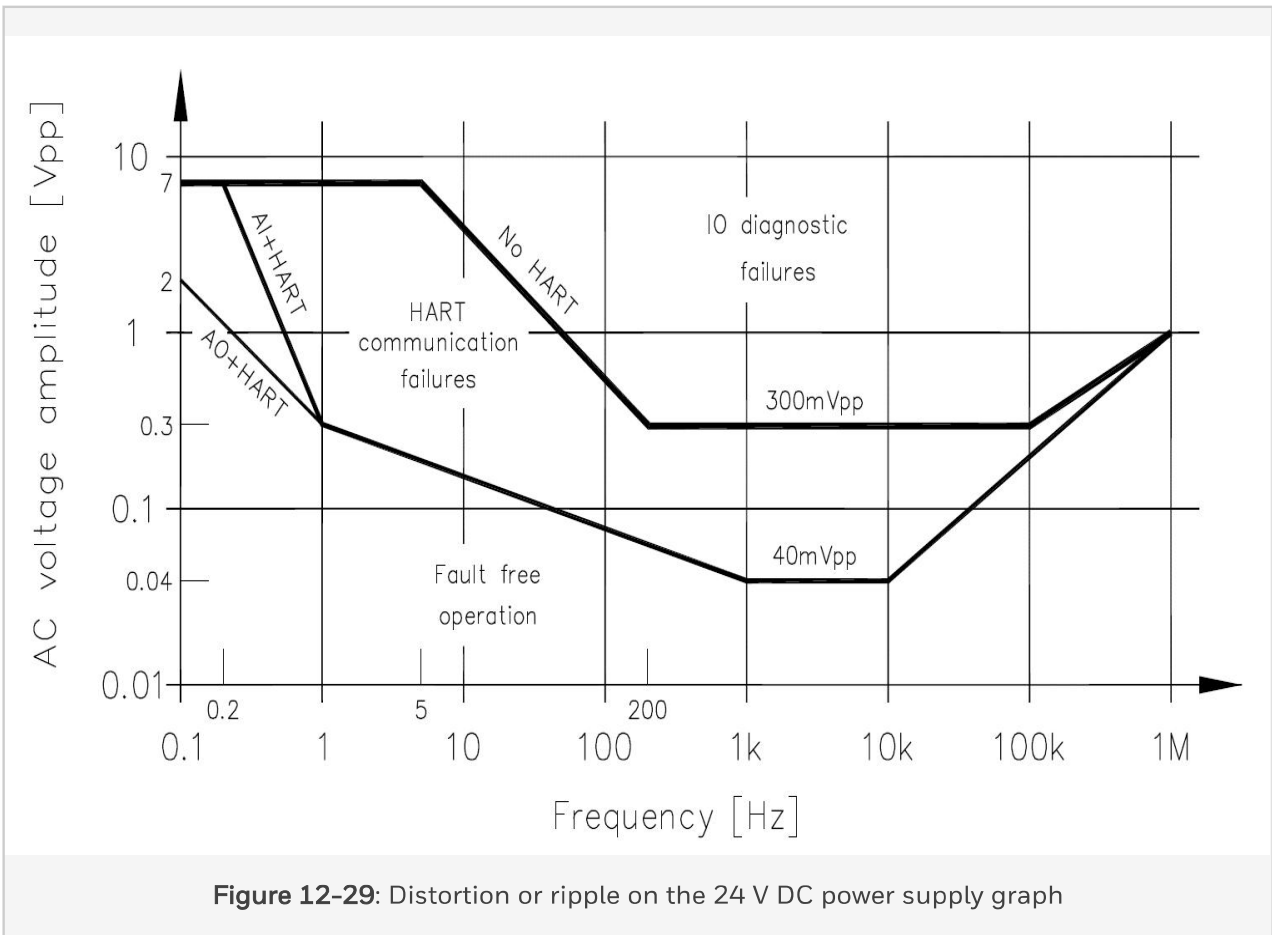

12.2.8 Module handling replacement

This sub section describes the procedures for removal and installation of a RUSLS-3224 module. See the below figure for relevant details.

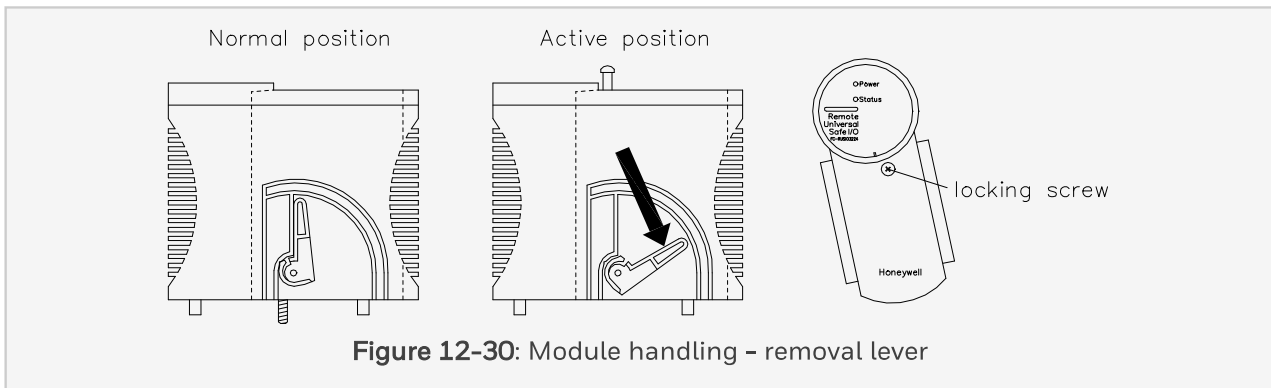

12.2.8.1 Removal of a RUSLS-3224 module

Do these steps in the order given to remove the subject RUSLS-3224 module:

1. On the IOTA, set the applicable switch (POWER 1 or POWER 2) to OFF. The Power LED (green) must go off.
2. Completely loosen the locking screw.
3. Press both (removal) levers at the sides of the module down *at the same time*. See Active Position in the above figure.
4. Remove the module from the IOTA.
5. Put the (removal) levers back in the upright (normal) position.

12.2.8.2 Installation of a RUSLS-3224 module

Do these steps in the order given to install the subject RUSLS-3224 module:

1. On the IOTA, make sure that the applicable switch (POWER 1 or POWER 2) is set to OFF.
2. On the module to be installed, make sure that the (removal) levers are in the upright (normal) position.
3. Hold the module in the correct position on the IOTA and carefully push it down on the corresponding connectors.
4. Tighten the locking screw.
5. On the IOTA, set the applicable switch (POWER 1 or POWER 2) to ON. The Power LED (green) must go on.

12 Universal Safety IO

12.2 RUSLS-3224

12.2.9 Technical data

The RUSLS-3224 module has the following specifications: