

ControlLogix I/O Modules Specifications

Bulletin 1756

Topic	Page
Summary of Changes	1
I/O Module Overview	3
AC Digital I/O Modules	7
DC Digital I/O Modules	45
Safety I/O Modules	147
Contact I/O Modules	163
Analog I/O Modules	169
HART I/O Modules	217
Compute Modules	241
Specialty I/O Modules	245
ControlLogix I/O Accessories	269

The ControlLogix® Architecture provides a wide range of input and output modules to span many applications, from high-speed digital to process control. The ControlLogix architecture uses Producer/Consumer technology, which allows input information and output status to be shared among multiple ControlLogix controllers.

Summary of Changes

This publication contains new and updated information as indicated in the following table.

Topic	Page
Corrected 1756-OF8H, 1756-OF8HK Technical Specifications	233
Corrected RTB Specifications	270

Rockwell Automation recognizes that some of the terms that are currently used in our industry and in this publication are not in alignment with the movement toward inclusive language in technology. We are proactively collaborating with industry peers to find alternatives to such terms and making changes to our products and content. Please excuse the use of such terms in our content while we implement these changes.

1756-IA16I, 1756-IA16IK

ControlLogix 120V AC isolated input module

Simplified Schematic

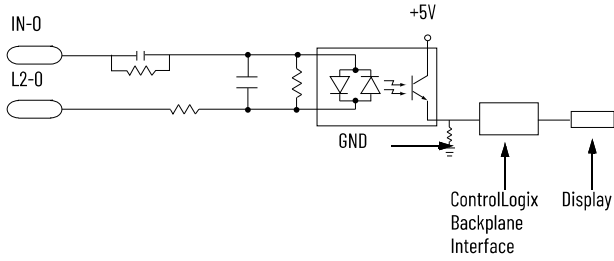

Additional jumper bars are available as catalog number 1756-JMPR.

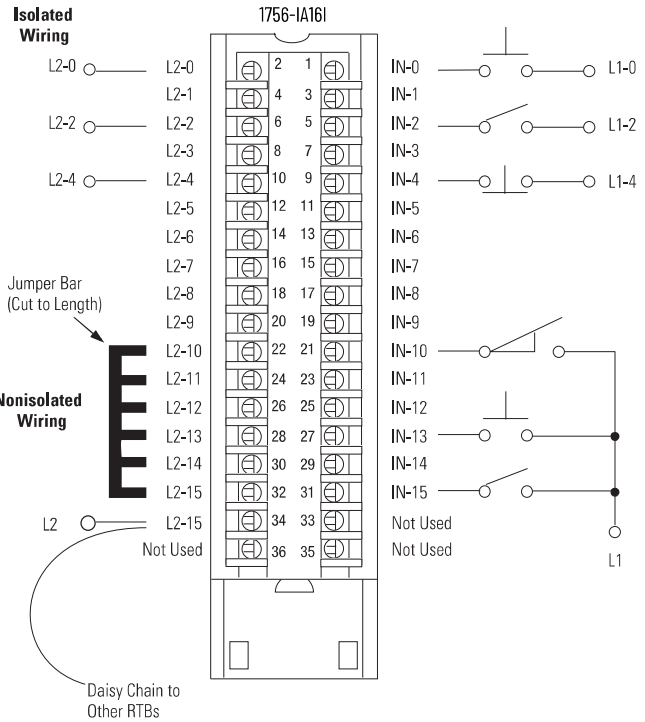
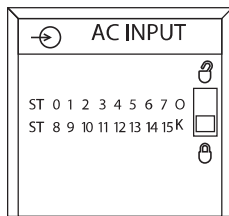

Technical Specifications

Attribute	1756-IA16I, 1756-IA16IK
Inputs	16 individually isolated
Voltage category	120V AC 50/60 Hz
Operating voltage range ⁽¹⁾	79...132V AC, 47...63 Hz
Input voltage, nom	120V AC 50/60 Hz
Input delay time (screw to backplane) Off to On	Hardware delay: 10 ms max + filter time User-selectable filter time: 1 ms or 2 ms
On to Off	Hardware delay: 8 ms max + filter time User-selectable filter time: 9 ms or 18 ms
Current draw @ 5.1V	125 mA
Current draw @ 24V	3 mA
Total backplane power	0.71 W
Power dissipation, max	4.9 W @ 60 °C (140 °F)
Thermal dissipation	16.71 BTU/hr
Off-state voltage, max	20V
Off-state current, max	2.5 mA
On-state current, min	5 mA @ 79V AC, 47...63 Hz
On-state current, max	15 mA @ 132V AC, 47...63 Hz
Inrush current, max	250 mA
Input impedance, max	8.8 kΩ @ 132V AC, 60 Hz
Cyclic update time	200 μs...750 ms
Change of state	Software configurable
Time stamp of inputs	±200 μs
Isolation voltage	125V (continuous), basic insulation type, inputs-to-backplane, and input-to-input
Module keying	Electronic, software configurable
Removable terminal block housing	1756-TBCH 1756-TBS6H
RTB keying	User-defined mechanical
Slot width	1
Wire category ⁽²⁾	1 - on signal ports
Enclosure type	None (open-style)
North American temperature code	T4A

(1) UL certification for 120V 50/60 Hz nominal. Rockwell Automation specified to 74...132V, 47...63 Hz.

(2) Use this conductor category information for planning conductor routing as described in the system-level installation manual. See the Industrial Automation Wiring and Grounding Guidelines, publication [1770-4.1](#).

Environmental Specifications

Attribute	1756-IA16I, 1756-IA16IK
Temperature, operating IEC 60068-2-1 (Test Ae, Operating Cold), IEC 60068-2-2 (Test Be, Operating Dry Heat), IEC 60068-2-14 (Test Nb, Operating Thermal Shock)	0...60 °C (32...140 °F)
Temperature, nonoperating IEC 60068-2-1 (Test Ab, Unpackaged Nonoperating Cold), IEC 60068-2-2 (Test Bb, Unpackaged Nonoperating Dry Heat), IEC 60068-2-14 (Test Na, Unpackaged Nonoperating Thermal Shock)	-40...+85 °C (-40...+185 °F)
Relative humidity IEC 60068-2-30 (Test dB, Unpackaged Damp Heat)	5...95% noncondensing
Vibration IEC 60068-2-6 (Test Fc, Operating)	2 g @ 10...500 Hz
Shock, operating IEC 60068-2-27 (Test Ea, Unpackaged Shock)	30 g
Shock, nonoperating IEC 60068-2-27 (Test Ea, Unpackaged Shock)	50 g
Emissions	IEC 61000-6-4
ESD immunity IEC 61000-4-2	6 kV contact discharges 8 kV air discharges
Radiated RF immunity IEC 61000-4-3	10V/m with 1 kHz sine wave 80% AM from 80...2000 MHz 10V/m with 200 Hz 50% Pulse 100% AM @ 900 MHz 10V/m with 200 Hz 50% Pulse 100% AM @ 1890 MHz 3V/m with 1 kHz sine wave 80% AM from 2000...2700 MHz
EFT/B immunity IEC 61000-4-4	±4 kV at 5 kHz on signal ports
Surge transient immunity IEC 61000-4-5	±1 kV line-line (DM) and ±2 kV line-earth (CM) on signal ports
Conducted RF immunity IEC 61000-4-6	10V rms with 1 kHz sine wave 80% AM from 150 kHz...80 MHz

Certifications

Certification ⁽¹⁾	1756-IA16I, 1756-IA16IK
cULus	UL Listed Industrial Control Equipment, certified for US and Canada. See UL File E65584. UL Listed for Class I, Division 2 Group A,B,C,D Hazardous Locations, certified for U.S. and Canada. See UL File E194810.
CE	European Union 2014/30/EU EMC Directive, compliant with: <ul style="list-style-type: none"> EN 61131-2; Programmable Controllers (Clause 8, Zone A & B) EN 61326-1; Meas./Control/Lab., Industrial Requirements EN 61000-6-2; Industrial Immunity EN 61000-6-4; Industrial Emissions European Union 2014/35/EU LVD Directive, compliant with EN 61131-2; Programmable Controllers (Clause 11)
RCM	Australian Radiocommunications Act, compliant with EN 61000-6-4; Industrial Emissions
FM	FM Approved Equipment for use in Class I Division 2 Group A,B,C,D Hazardous Locations
KC	Korean Registration of Broadcasting and Communications Equipment, compliant with Article 58-2 of Radio Waves Act, Clause 3
UKCA	In conformity with the following UK Statutory Instruments and their amendments: <ul style="list-style-type: none"> 2016 No. 1091, Electromagnetic Compatibility Regulations 2016 No. 1101, Electrical Equipment (Safety) Regulations 2016 No. 1107, Equipment and Protective Systems Intended for Use in Potentially Explosive Atmospheres Regulations 2012 No. 3032, Restriction of the Use of Certain Hazardous Substances in Electrical and Electronic Equipment
Morocco	In conformity with the following regulations: <ul style="list-style-type: none"> Arrêté ministériel n° 6404-15 du 1 er muharram 1437 (15 octobre 2015) Équipements électriques destinés à être utilisés sous certaines limites de tension Arrêté ministériel n° 6404-15 du 29 ramadan 1436 (16 juillet 2015) Compatibilité électromagnétique des équipements

(1) When product is marked. See the Product Certification link at rok.auto/certifications for Declarations of Conformity, Certificates, and other certification details.

1756-IA32, 1756-IA32K

ControlLogix AC (74...132V) input module

Simplified Schematic

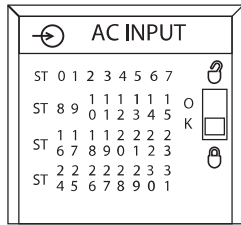
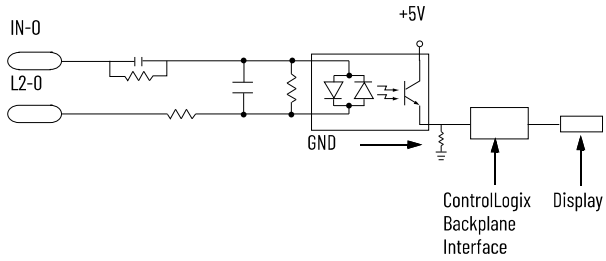

1756-IA32

